



# **ROLL UP DOOR TRADITIONAL HANDLE BAR INSTALLATION INSTRUCTIONS**

**\*\*\*\*\* READ ALL INSTRUCTIONS BEFORE \*\*\*\*\*  
ATTEMPTING INSTALLATION OF  
YOUR ROLL UP DOOR PRODUCT**

**DOC NO: INST00001  
CHG: STB**

**REV: 15  
APR: MTA ECR: ECR21187 DATE: 10/13/21**

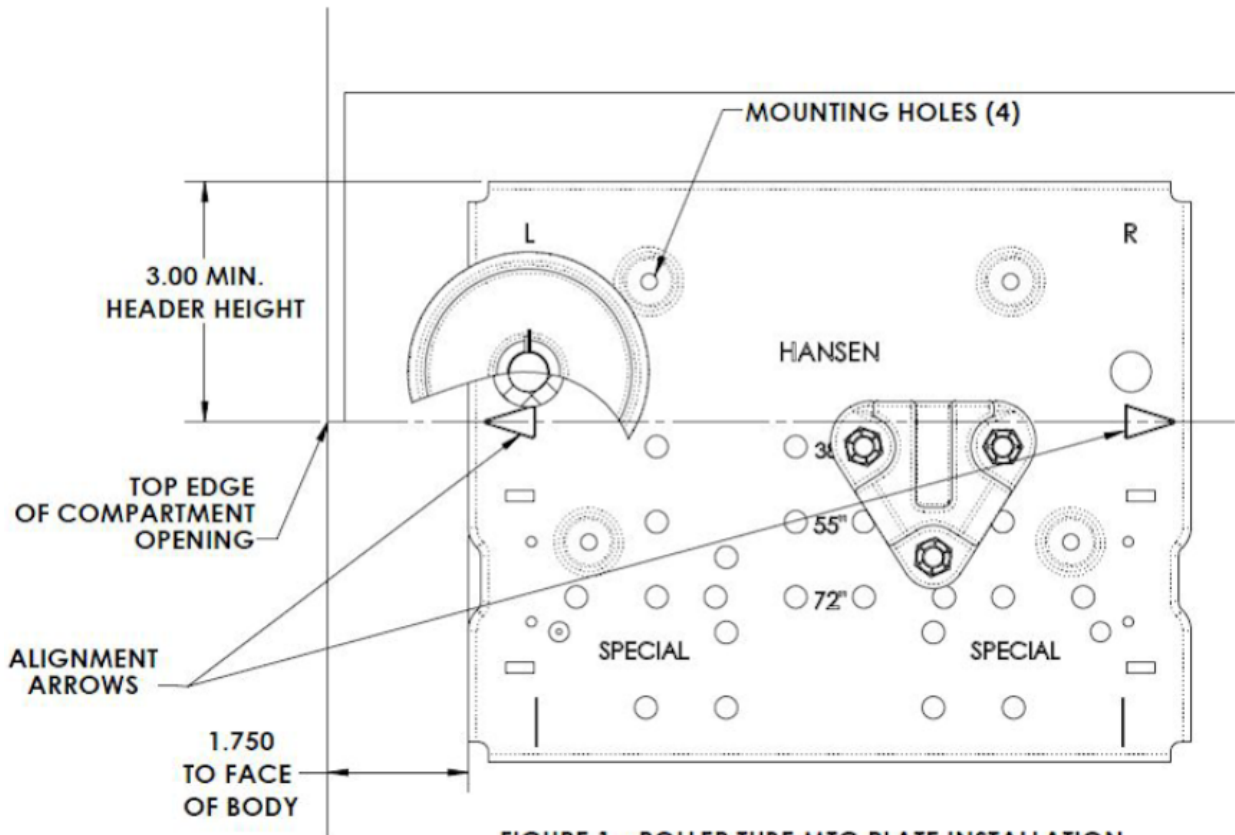
## TABLE OF CONTENTS

<u>Description</u>	<u>Pages</u>
<b>Section 1 – Basic Installation</b>	<b>3 – 19</b>
<b>Section 2 – Optional Features</b>	
<b>Door Ajar Switch Wiring</b>	<b>20 - 22</b>
<b>Pull Cord</b>	<b>23 - 24</b>
<b>10mm LED Compartment Lights</b>	<b>25</b>
<b>Drip Pan</b>	<b>27</b>
<b>Electric Locking</b>	<b>28</b>
<b>Emergency Inside Release</b>	<b>29</b>
<b>Handlebar With LED Back Lighting</b>	<b>30</b>
<b>Section 3 – Care And Maintenance</b>	<b>31</b>
<b>Appendix</b>	<b>32</b>

## **SECTION 1 – Basic Installation**

### **Step 1 – Mounting Plate / Bottom Sill Installation**

The arrows stamped in the roller tube mounting plate sub-assemblies should be aligned with the top of the compartment edge, and the front edge of the plate spaced 1-3/4" back from the front face of the vehicle body as shown. It is recommended to use a carpenter's square or other right angle tool to lay out a wax pencil line or tape line for this. See Fig. 1.



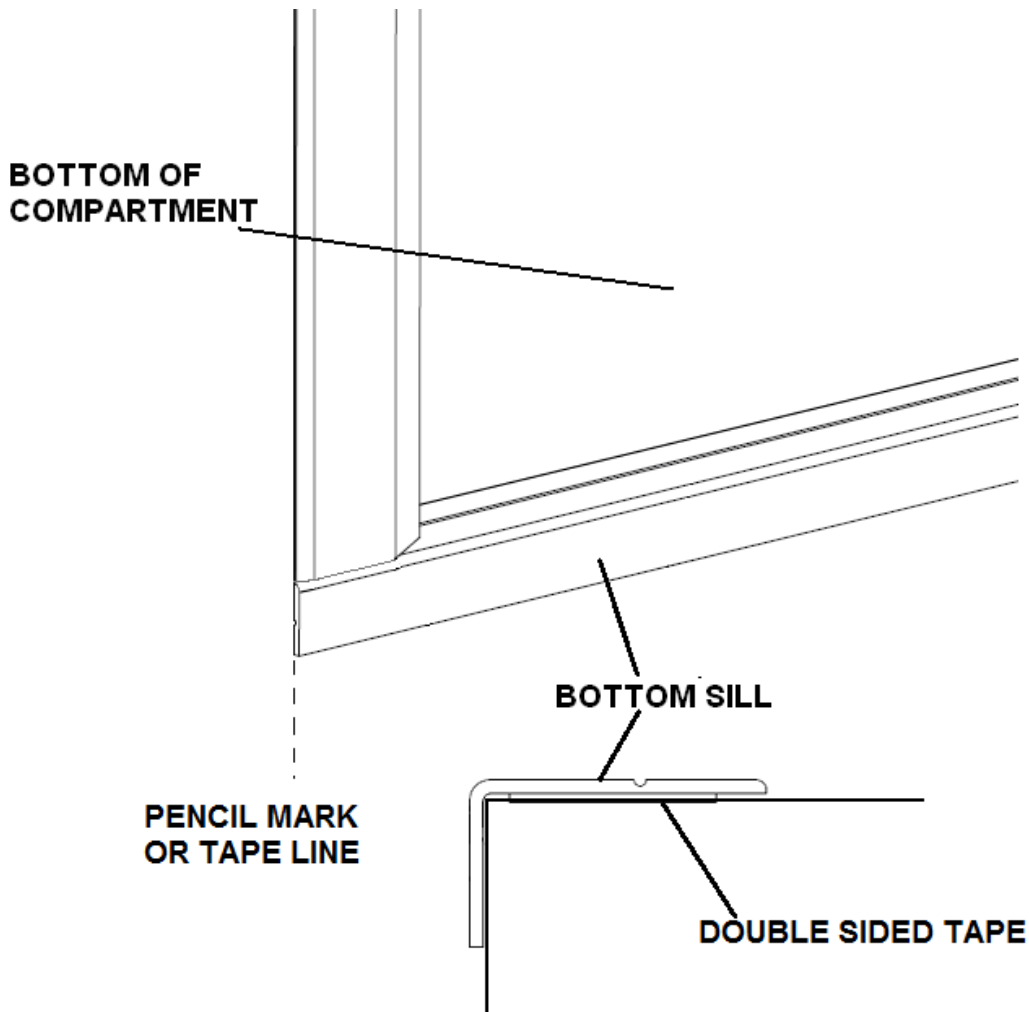
**FIGURE 1 - ROLLER TUBE MTG PLATE INSTALLATION**

With the plate held in position, mark the four mounting hole locations on the compartment side wall. Drill one hole and secure the mounting plate with a #10 sheet metal screw or other fastener suitable for the material and thickness of the body. The head of the fastener must not protrude above the face of the mounting plate or the curtain could hit it as the door rolls up. Use the mounting plate as a drill guide to drill the remaining three holes. Note that the left and right side compartment walls must be flush with the left and right edges of the compartment opening; otherwise the mounting plates will have to be shimmed up until the underside of the mounting plates are flush with the compartment edge. Repeat this process for the other roller tube mounting plate on the other side of the compartment.

(Continued →)

If your door does not include the optional bottom sill, the following step may be skipped. Otherwise trim the rubber side seals at the bottom of the guide channels and test fit them in the aperture of the body. Keeping each of the guide channels firmly pressed against the compartment wall, make a small pencil or tape mark on the left and right side edge of one of the guide channels to locate the edges of the bottom sill.

Remove the guide channels from the opening and peel the backing from the double sided tape on the bottom of the sill. Taking care to center it between the pencil marks (the sill might be slightly wider or narrower than the pencil marks depending on your apertures width tolerance), adhere the sill to the bottom of the compartment opening as shown, pressing firmly down on the tape to secure it to the body. A small drilling groove is provided to utilize additional fasteners (not supplied) for the sill if desired. See fig 2.

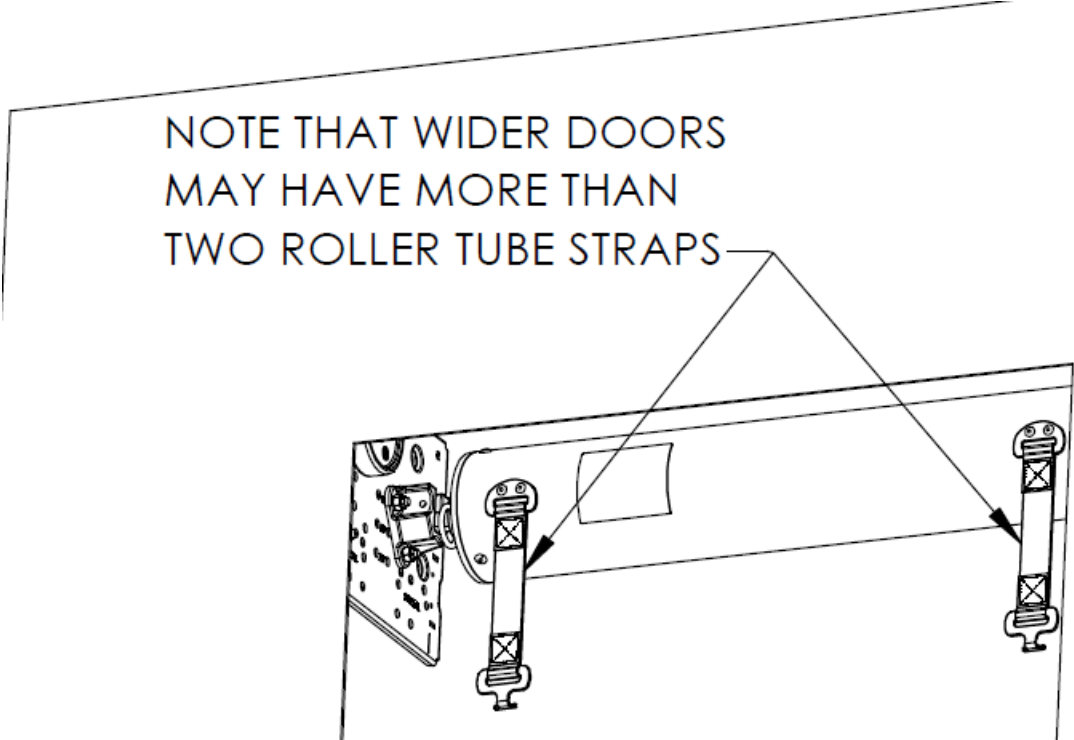


**Fig. 2 – Bottom sill installation**

(Continued →)

**Step 2 – Roller Tube Installation**

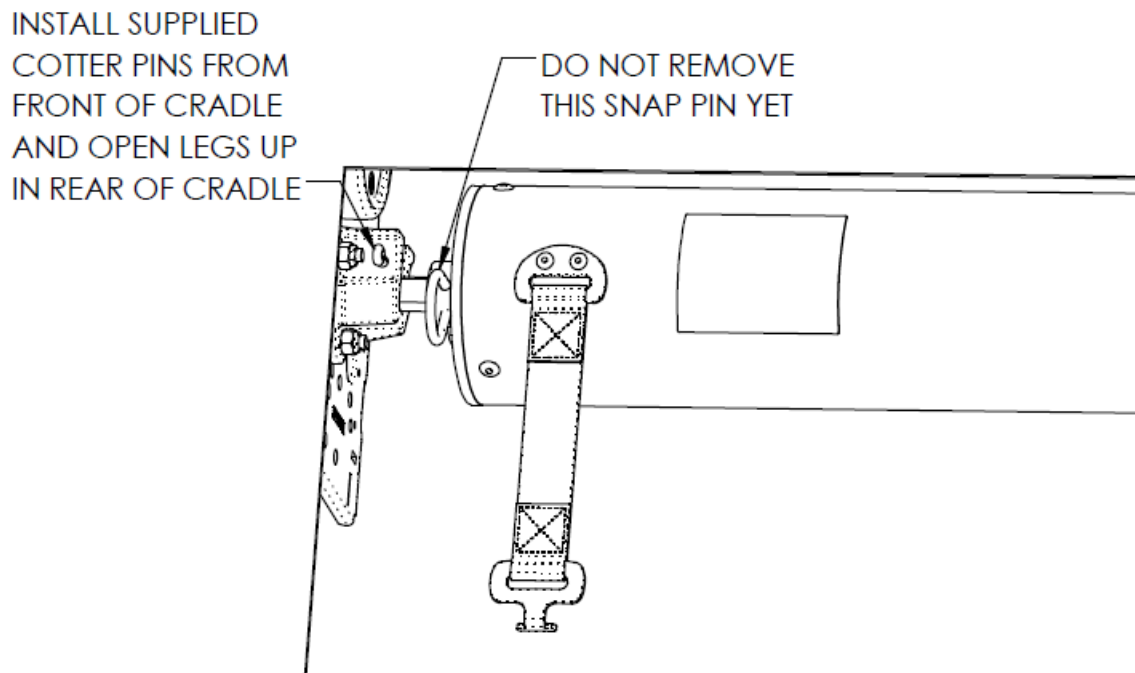
Install the roller tube sub-assembly in between the pre positioned cradles on the mounting plates with the straps facing forward as shown in Fig. 3.



***Fig. 3 – Roller tube installation***

(Continued →)

Secure the roller tube shaft in the cradles on both sides with the cotter pins supplied with the mounting plates. Do NOT remove the spring retaining pin passing through the roller tube shaft on the left side of the roller tube sub-assembly at this time. The roller tube is under spring tension and this pin maintains that tension until the door curtain is installed. See Fig. 4.



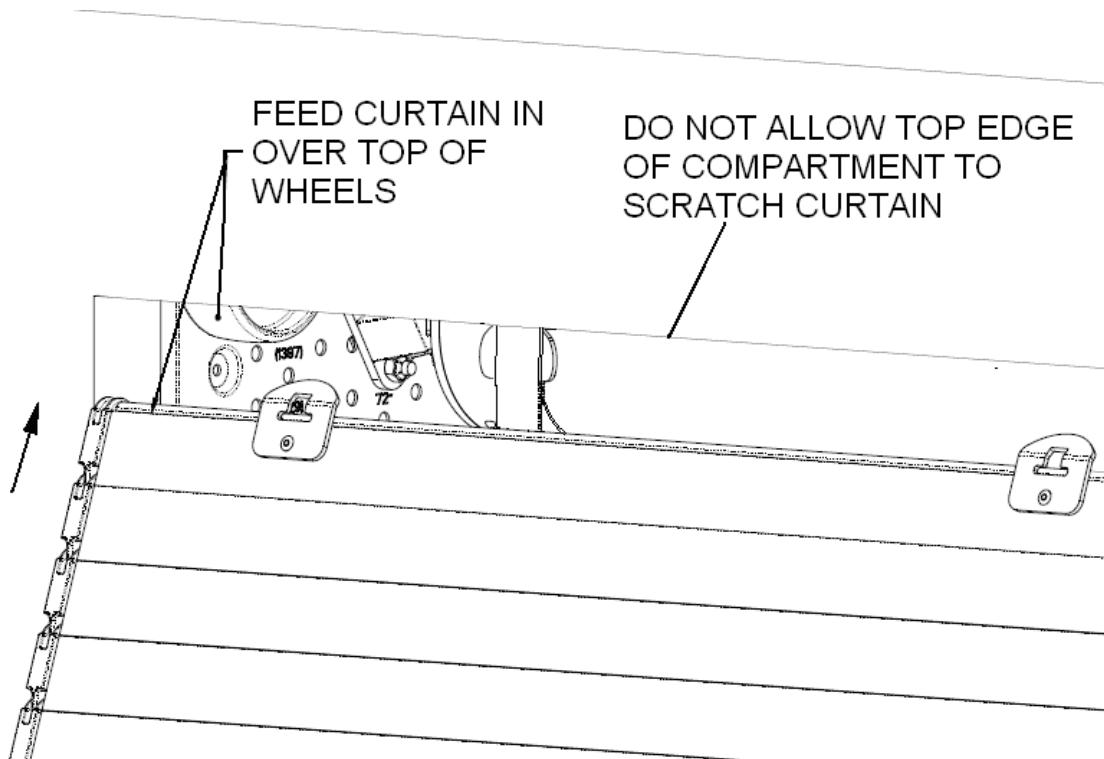
**Fig. 4 – Securing roller tube**

(Continued →)

### **Step 3 – Curtain Installation**

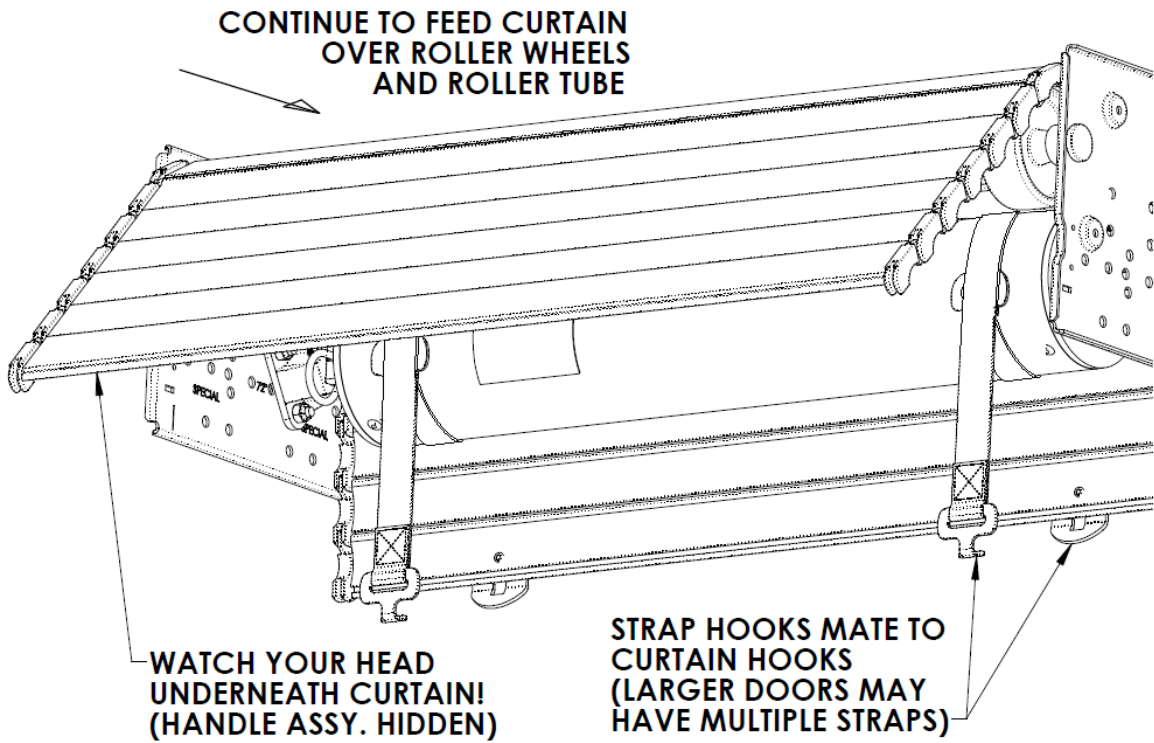
Slide the top of the curtain through the top of the compartment opening and over the top of the curtain roller wheels on the mounting plates as shown. Notice the brackets riveted to the top of the curtain denote the edge of the curtain to be fed into the compartment. See Fig. 5.

Continue to feed the curtain over the top of the roller tube as shown in Fig. 6, until enough has drooped over the back of the roller tube to expose the curtain brackets and hold the handle bar at the top of the compartment.



***Fig. 5 – Initial curtain installation***

(Continued →)



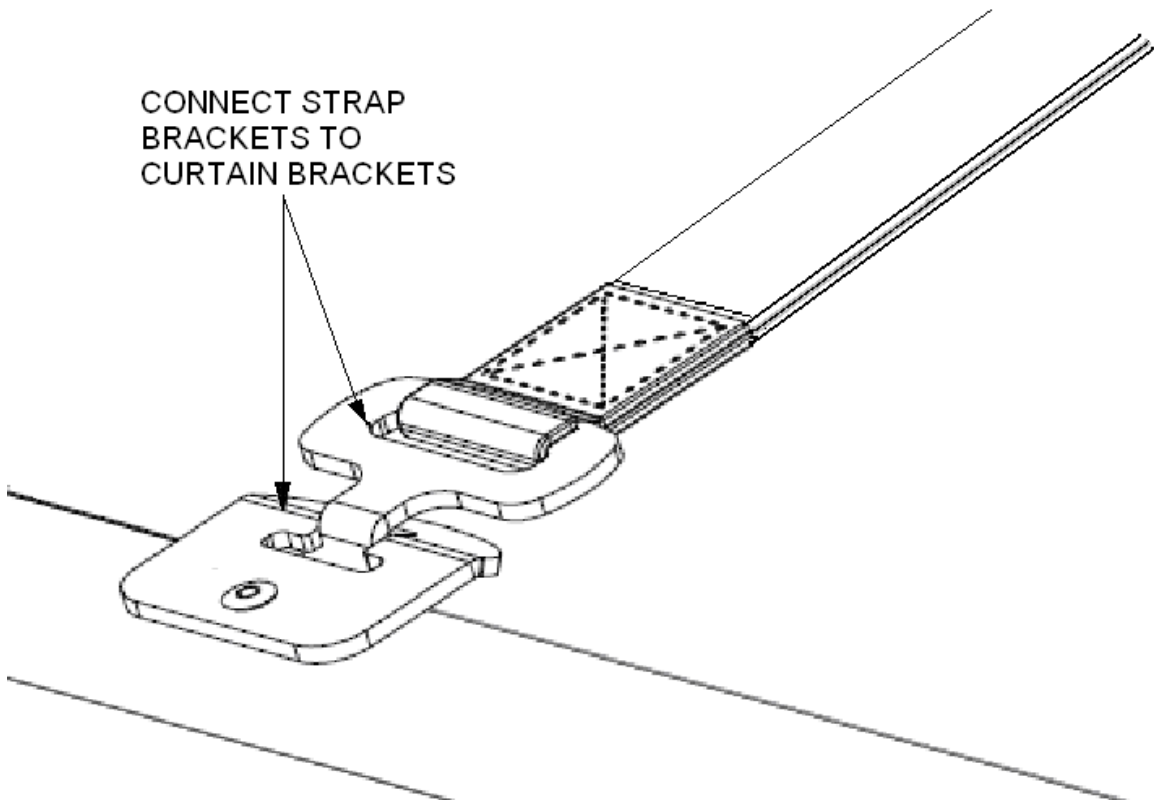
**Fig. 6 – Feed curtain over top of wheels and tube**

Hook the male brackets on the strap into the female brackets riveted to the top of the curtain as shown in Fig 7. Allow the straps to wrap around the back of the roller tube.

For large doors it may be helpful to have one installation technician inside the compartment to attach the straps while one or two others feed the curtain in over the top of the roller wheel and roller tube:

(Continued →)





***Fig. 7 – Attach roller tube straps to curtain brackets***

(Continued →)

Removing the retaining pin from Fig. 4 will release spring tension on the tube and the spring will act as a counter balance to the weight of the curtain. When removing this pin, the installation technician should use a firm hand to pull on and maintain tension on top edge of the curtain to relieve spring pressure on the pin, making it easier to pull out. Use a suitable pair of pliers with sufficient grip. Larger doors may require two installation technicians to accomplish this task.

*Gently* release the spring tension on the roller tube with the hands and allow the curtain to wrap itself up on the roller tube.

**Watch fingers for pinch points during this step. Use of suitably protective work gloves is strongly recommended.**

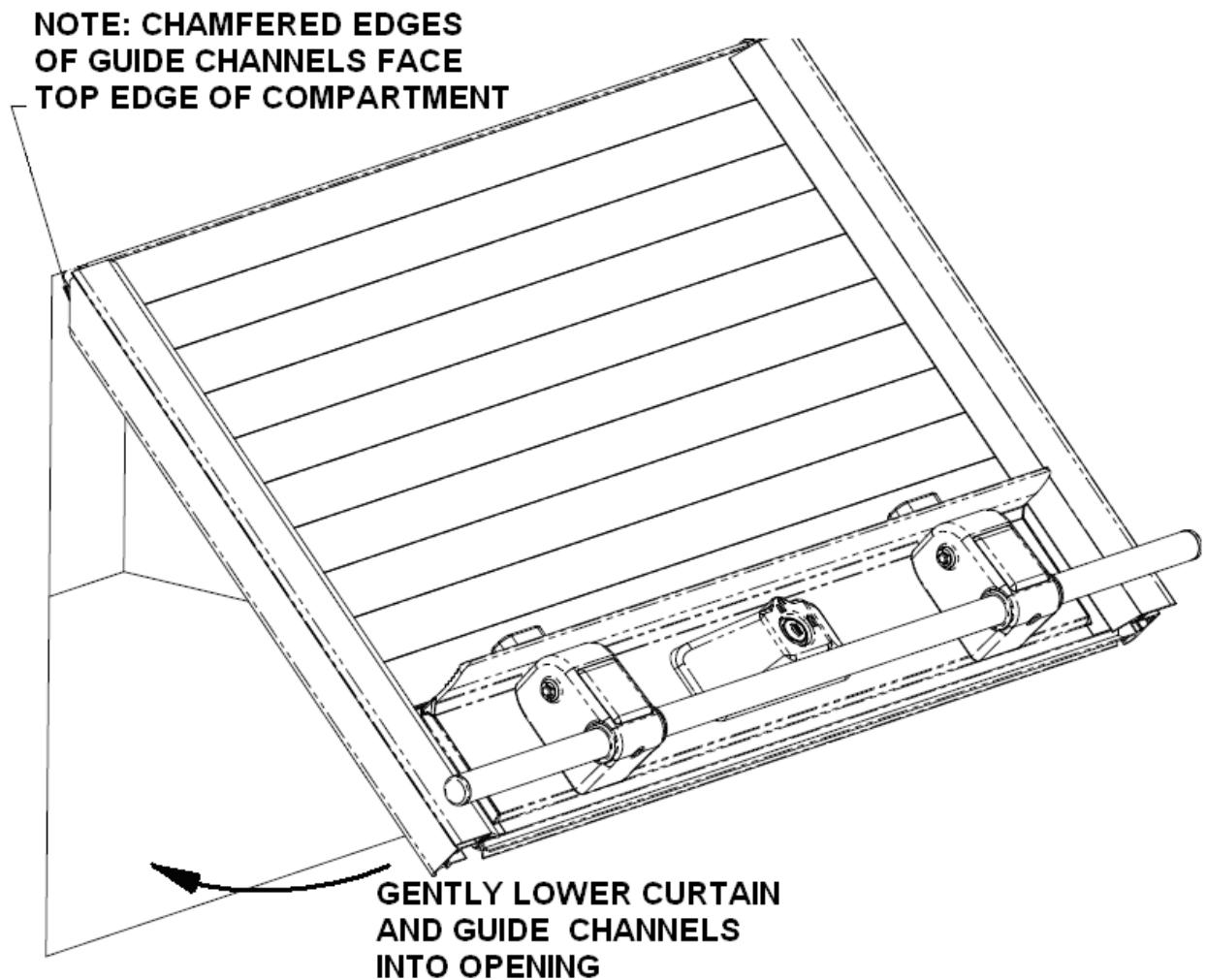
## **\*\*WARNING\*\***

**THE ROLLER TUBE ON YOUR DOOR COMES FROM THE FACTORY WITH A PRESET AMOUNT OF SPRING TENSION FROM AN INTERNAL TORSIONAL SPRING. FAILURE TO RELEASE THIS TENSION IN A CONTROLLED MANNER CAN RESULT IN PERSONAL INJURY AND DAMAGE TO YOUR ROLL UP DOOR. DO NOT ATTEMPT TO ADJUST THE TENSION ON THE ROLLER TUBE AS IT COMES PRESET FROM THE FACTORY.**

(Continued →)

## **Step 5 – Guide Channel Installation**

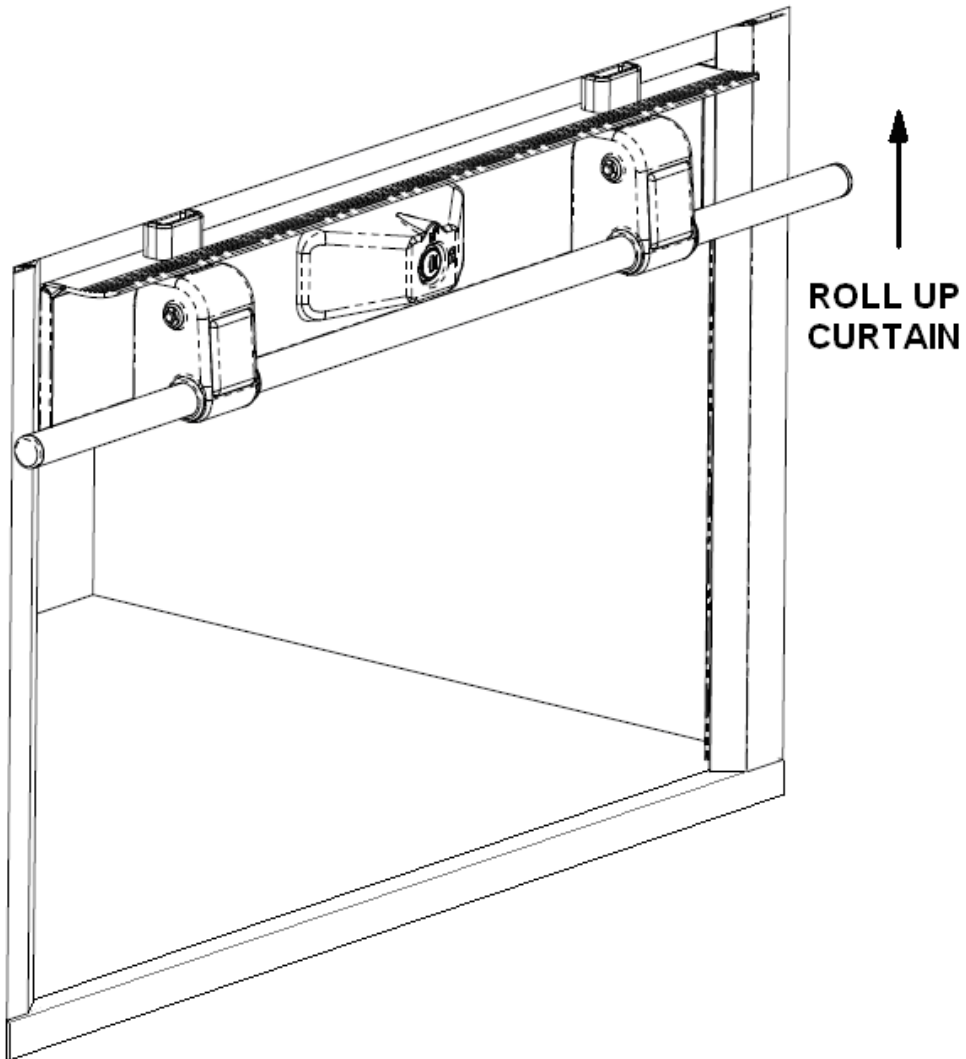
Slide the guide channels with side seals onto the sides of the curtain. Note that the guide channels are handed. The large, rearward facing chamfered end of the guide channel goes at the top of the vehicle compartment. With both guide channels on either side of the curtain, gently lower the curtain into the opening until the front flanges on the guide channels are resting against the front face of the vehicle body (Fig. 8).



***Fig. 8 – Installing the guide channels (bottom sill not shown)***

(Continued →)

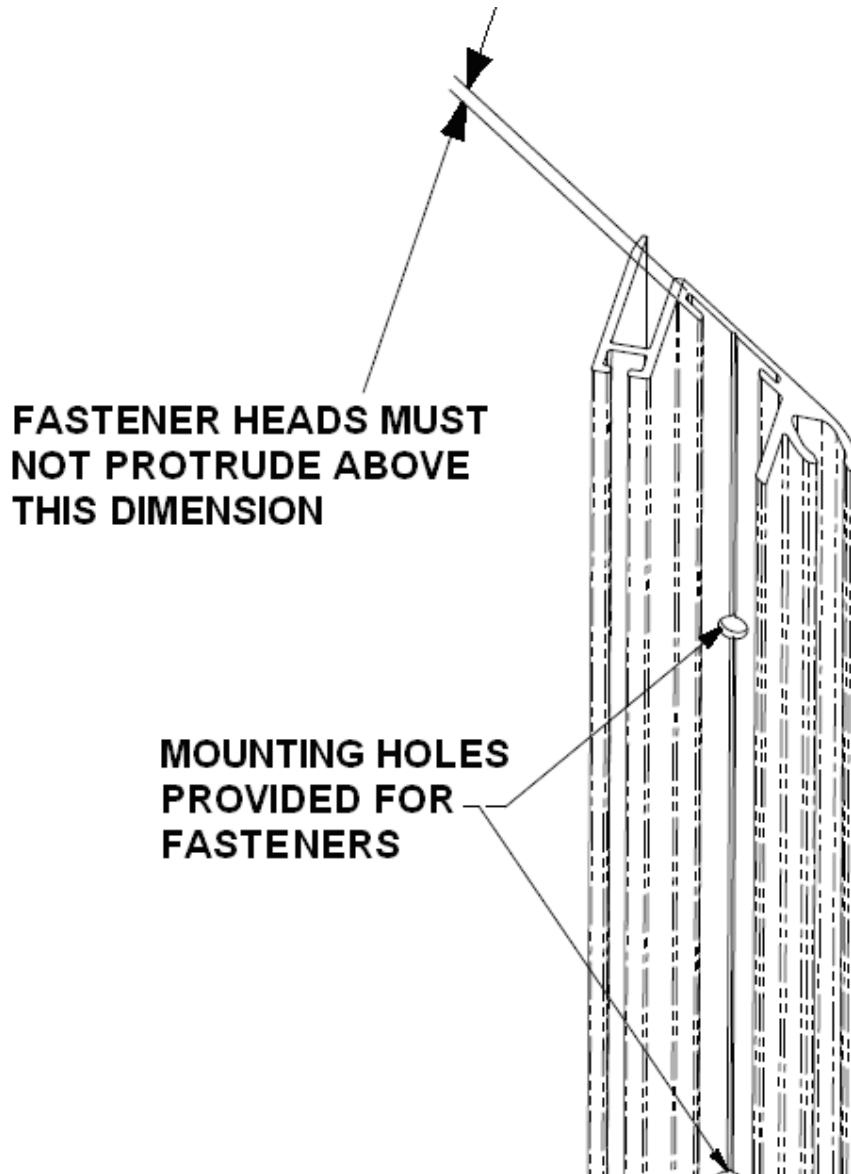
Now raise the door fully (Fig. 9). The curtain should coil freely around the roller tube.



**Fig. 9 – Raise curtain to install fasteners for guide channels**

(Continued →)

With the curtain open, secure the guide channels to the sides of the vehicle compartment with #8 sheet metal screws or other fastener suitable for the material and thickness of the body. These should go down in the recessed slot provided in the guide channels (see Fig. 10). The heads of the fasteners must not protrude above this slot or rough operation of the door will be the result. Note that if your roll up door has the locking feature shown in these illustrations that a 1/8" diameter hole will be pre-drilled about 2 inches from the bottom of each guide rail. These are pilot holes for drilling the intercept holes for the locking rods and must be kept clear for the final installation steps.



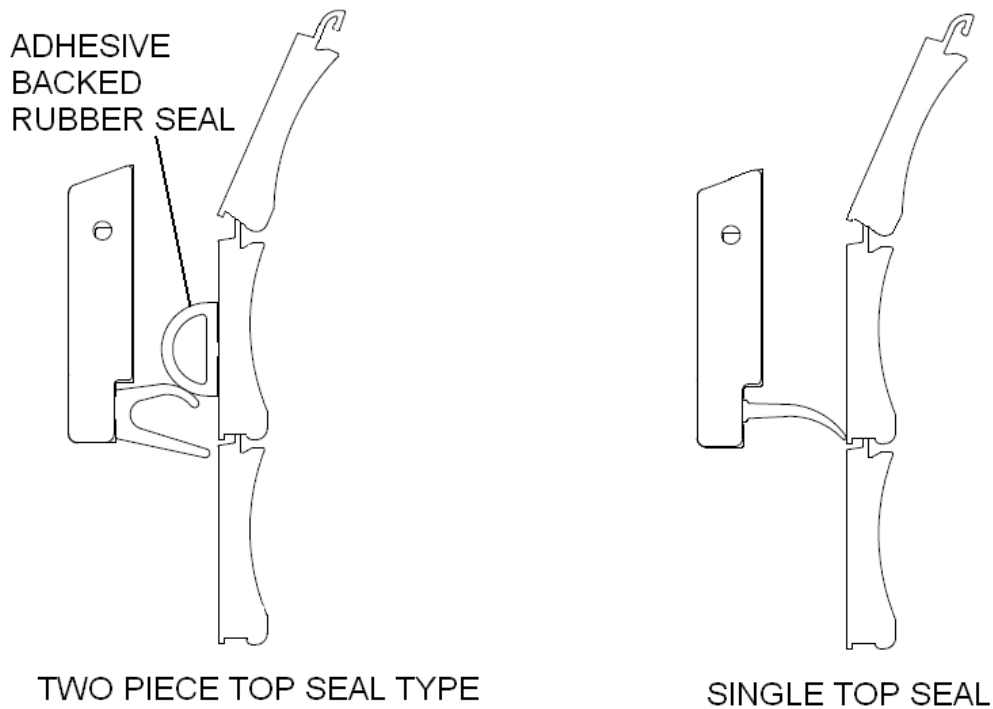
**Fig. 10 – Securing the guide channels**

(Continued →)

## **Step 6 – Drip Rail Installation**

Note that the “step” in the drip rail laps over the top of the guide channels. Trim the top seal in the drip rail to fit in the remaining opening between the guide channels, and trim the side seals on the guide channels to butt up against the top seal in the drip rail. See Figs 12 and 13.

If your roll up door includes the optional two piece top seal, the adhesive backed rubber seal must be applied to the curtain before securing the drip rail to the body. Fully close the door, and temporarily holding the drip rail and top seal in place, Use a light pencil mark or temporary piece of tape to locate the rubber seal on the curtain so that it intercepts at least one of the fingers of the extruded portion of the top seal when the door is closed. See Fig. 11. Do not apply the adhesive backed seal across the crack between the door curtain laths. If you have the single piece type top seal, you may proceed without this step.

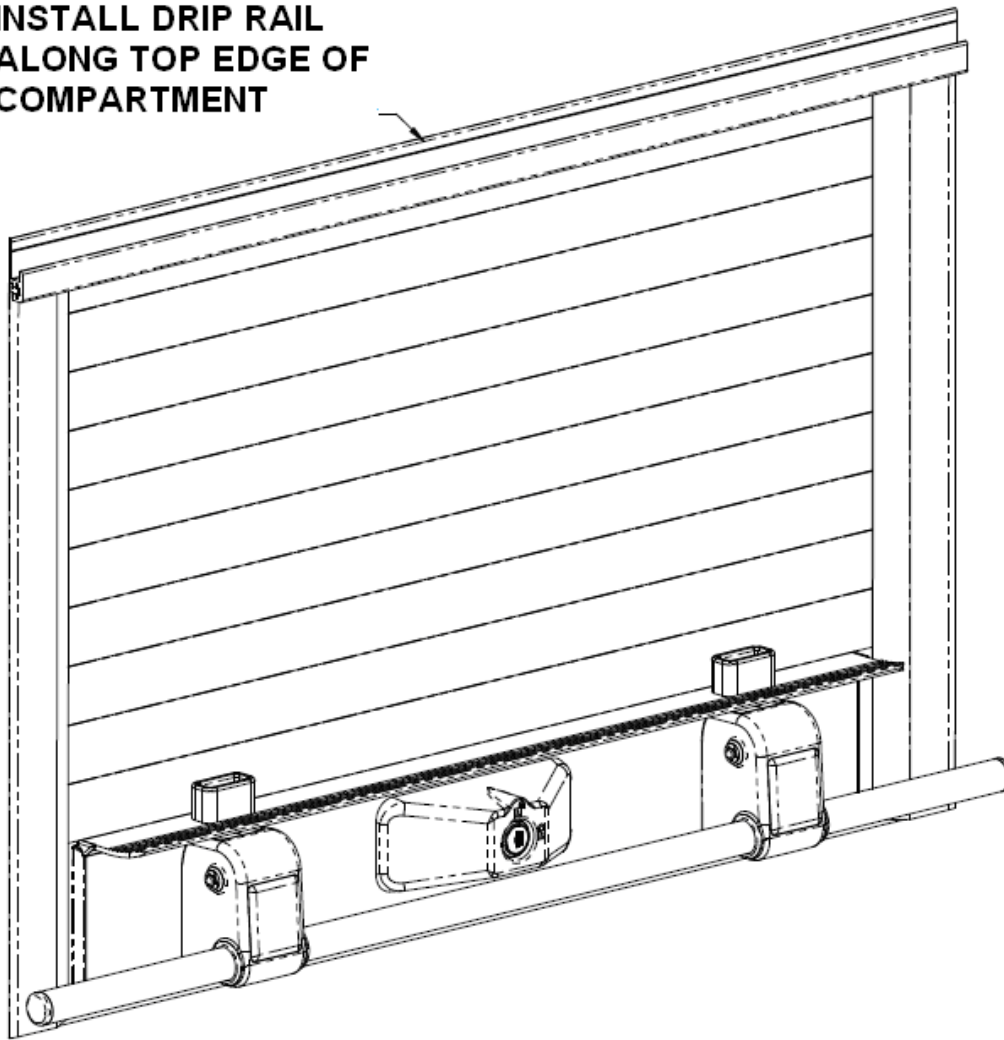


***Fig. 11 – Top seal types and configurations***

(Continued →)

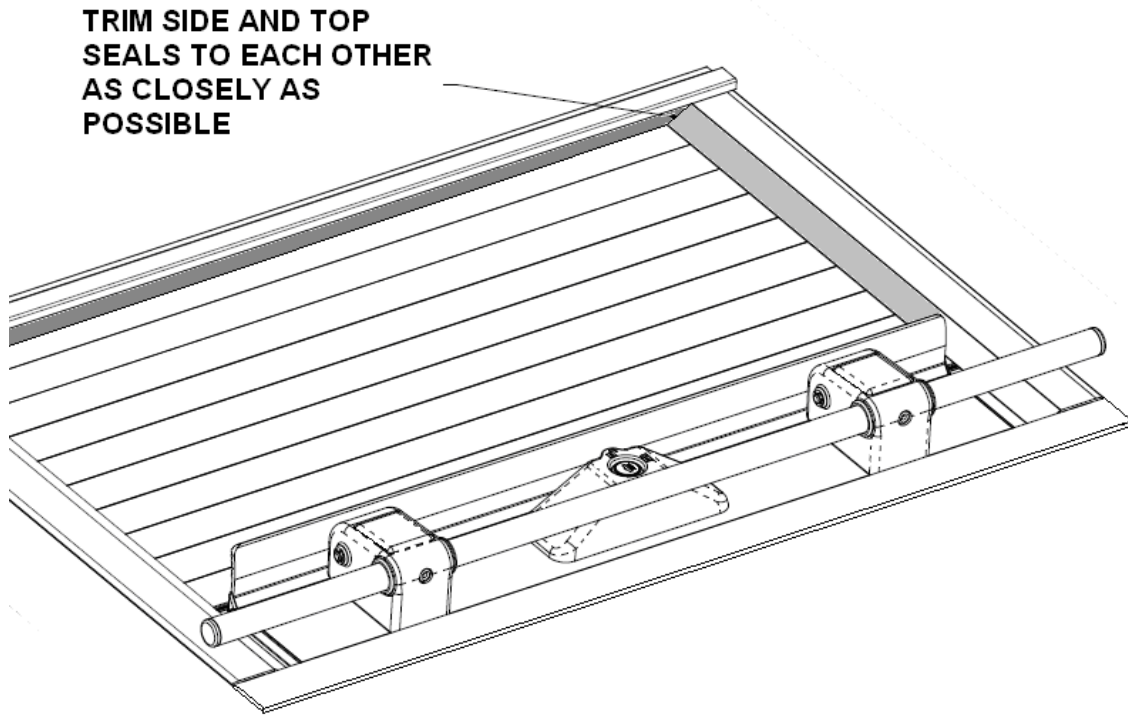
A groove for locating drilling points is provided in the drip rail (see Fig. 14). It is recommended that this be done using drill bits with stops on them, and that the door closed and latched to ensure the bit does not scratch the visible face of the door. Drill starting holes for a 3/8" long sheet metal screw (#8 recommended). Screws longer than this may damage the seal or scratch the door. A spacing of between 12 to 16 inches is recommended for fasteners. The mounting surface of the drip rail should have some silicone sealant applied around the mounting holes in order to aid with water resistance.

**INSTALL DRIP RAIL  
ALONG TOP EDGE OF  
COMPARTMENT**

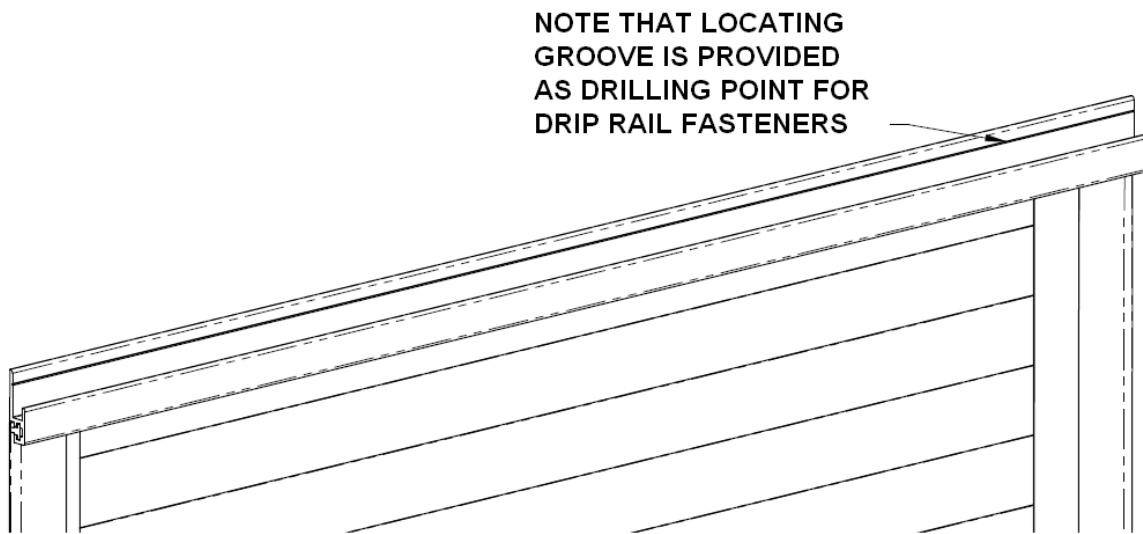


***Fig. 12 – Drip rail installation***

(Continued →)



**Fig. 13 – Trim top and side seals to fit**

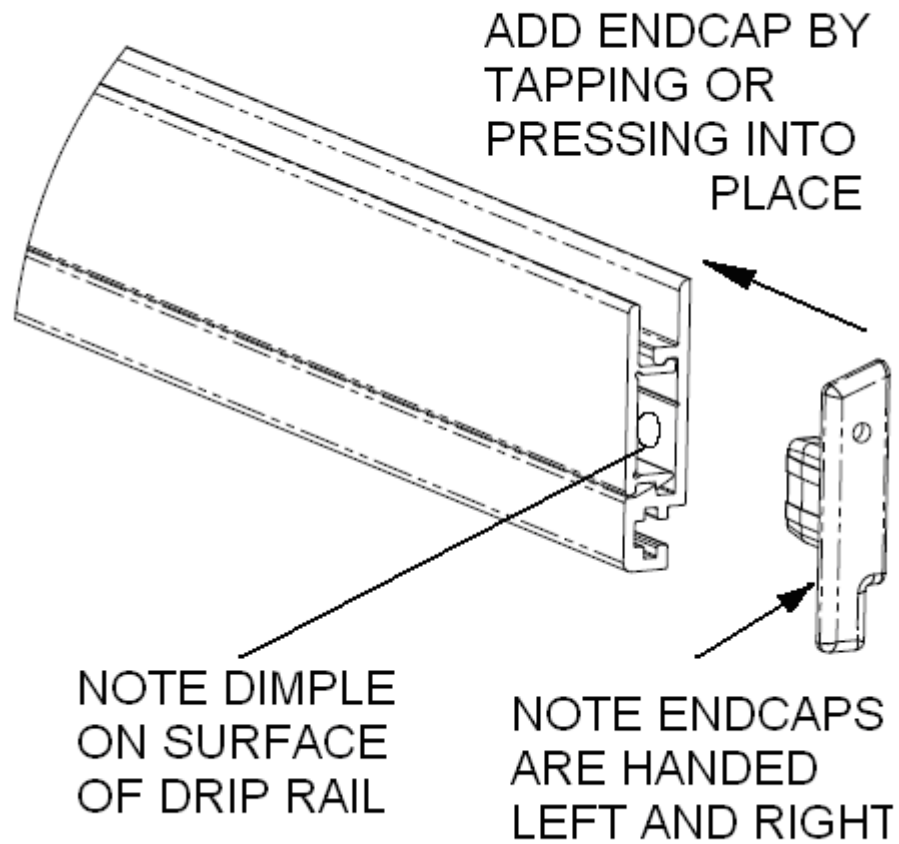


**Fig. 14– Drilling guide for drip rail**

(Continued →)



If your drip rail includes the optional cover plate, the cover must be installed by sliding and tapping it in from the side. Use a soft block of wood against the aluminum extrusion to avoid denting or scratching it. After the cover is in place, the end caps may be tapped into the end in the same manner as the cover. Notice that the end caps are handed left and right, and that the hole in the back side of the end caps tongue section mates up with the dimple in the drip rail. See Fig. 15.

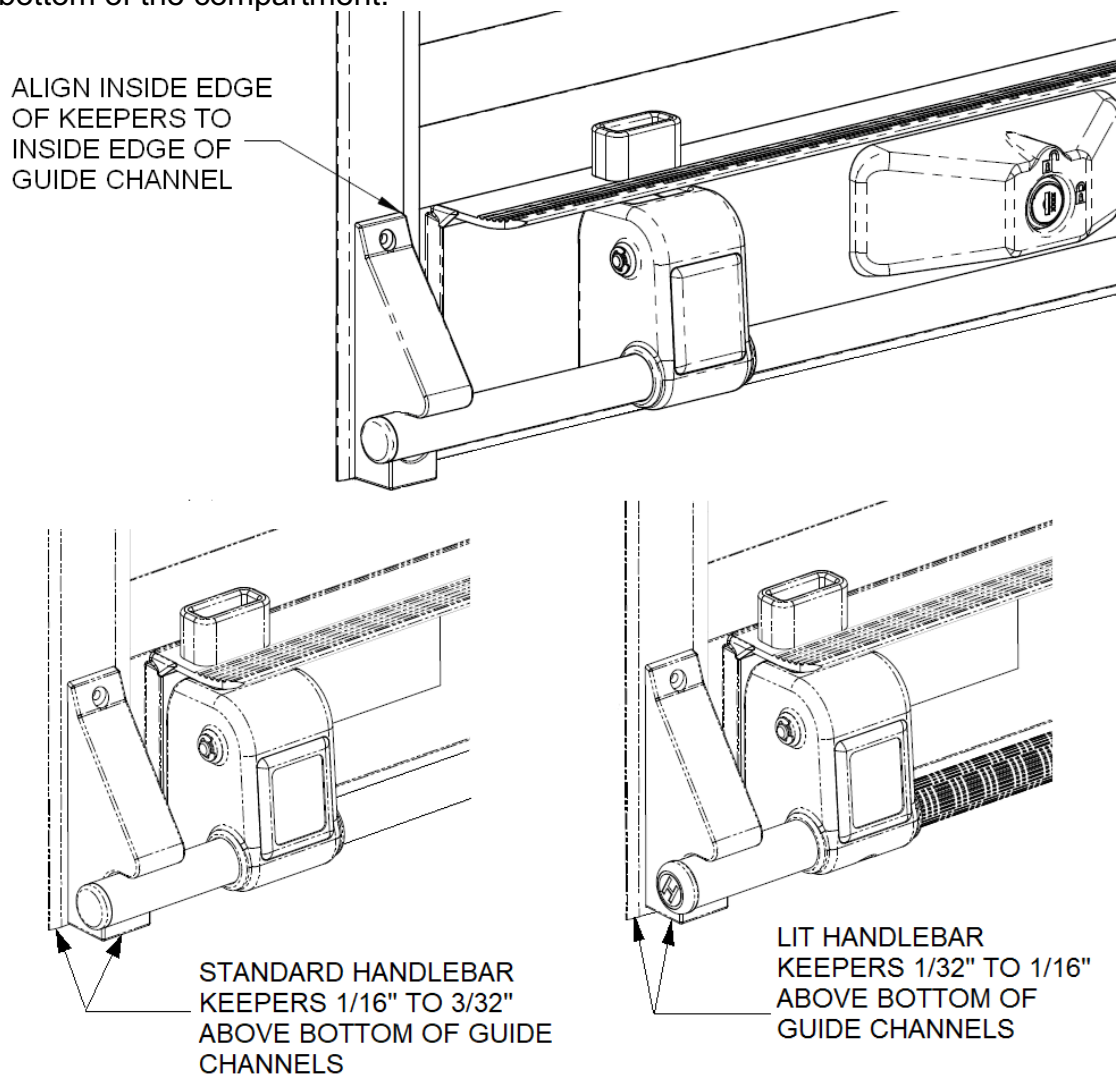


**Fig. 15– Optional drip rail cover plate and end caps**

(Continued →)

## **Step 7 – Final Assembly**

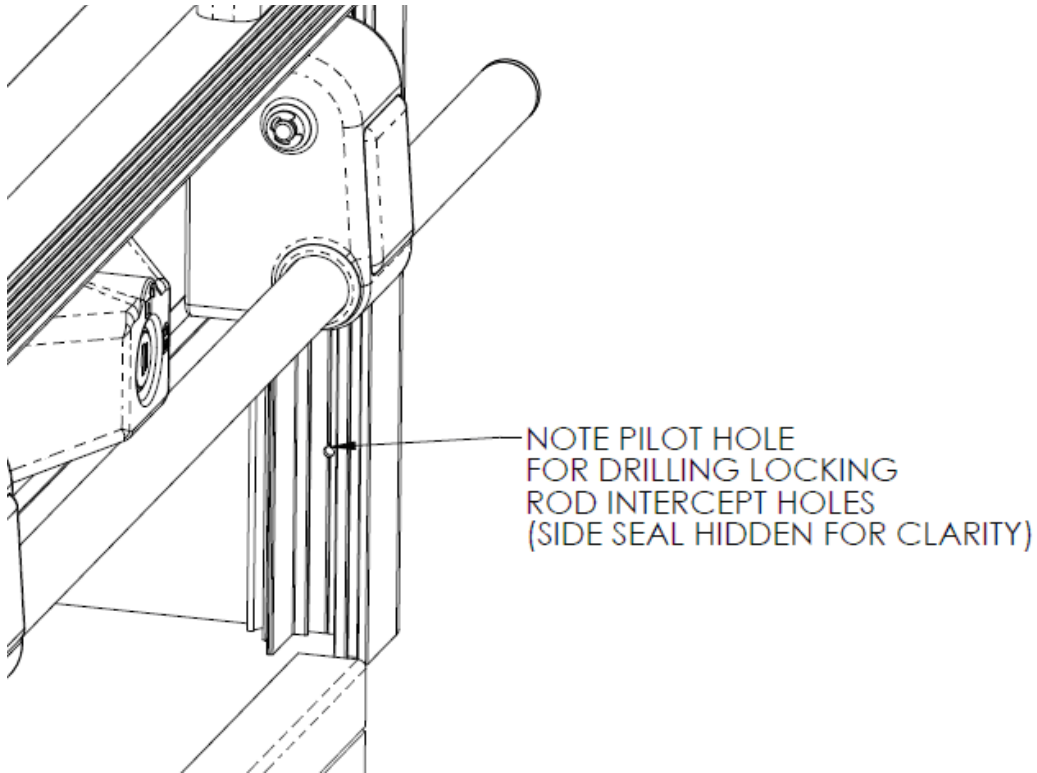
Place the supplied handle bar keepers in their proper position, resting against the handle bar and guide channels as shown. Depending on the handlebar style of your door, the approximate location of the bottom of the keeper blocks to the bottom of the guide channels is shown in Fig. 16. The inside edge of the keepers should be around 1/16" from the rubber side seal and aligned parallel to it. Fasten the keepers to the guide channels with the supplied 5/32" rivets. It is recommended to use silicone sealant around the mounting holes on the rear surface of the keepers prior to attaching them to improve water resistance. Now pull the door down and close it, making sure the handle bar easily snaps past the keepers and into the latched position (see Fig 16). Check to ensure that the bottom seal on the door has good compression against the bottom of the compartment.



**Fig. 16 – Handle bar keepers**

(Continued →)

If your roll up door includes the 2 point locking feature as shown in the illustrations, use the provided 1/8" dia. pilot holes to place a small amount of modeling clay or plumbers putty. Close and latch the door and attempt to lock it. This will mark the putty precisely. Use a 3/8" drill at this mark to drill out the locking rod intercept holes. When the holes have been drilled, close and latch the door and test the locking rods for proper functionality. If any resistance is encountered by the locking rods, enlarge the holes slightly until proper engagement is achieved. See Fig. 17.



**Fig. 17 – Locking rod intercept holes**

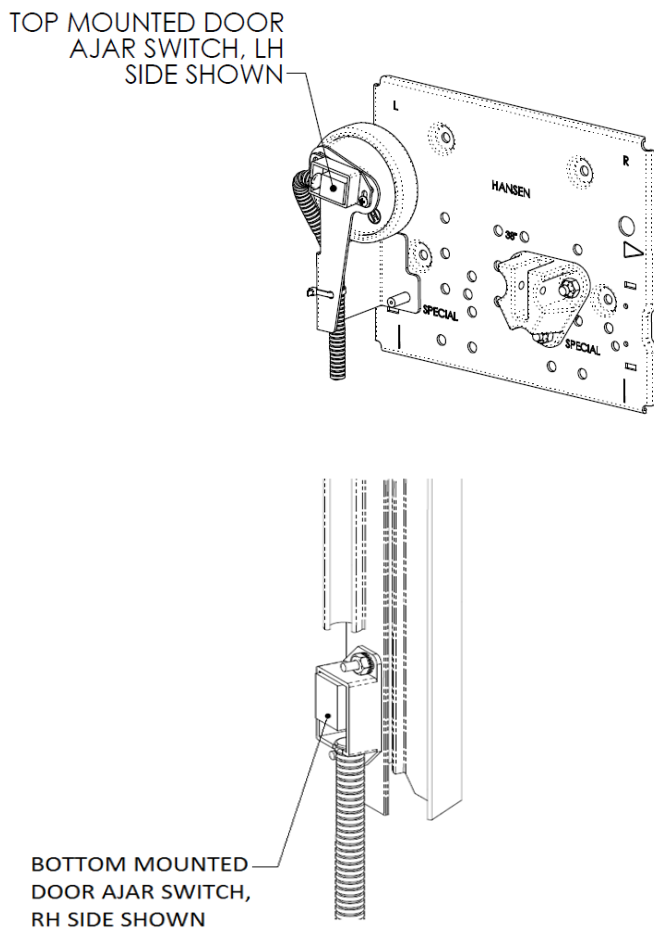
(Continued →)

## **SECTION 2 – Optional Features**

### **Door Ajar Switch**

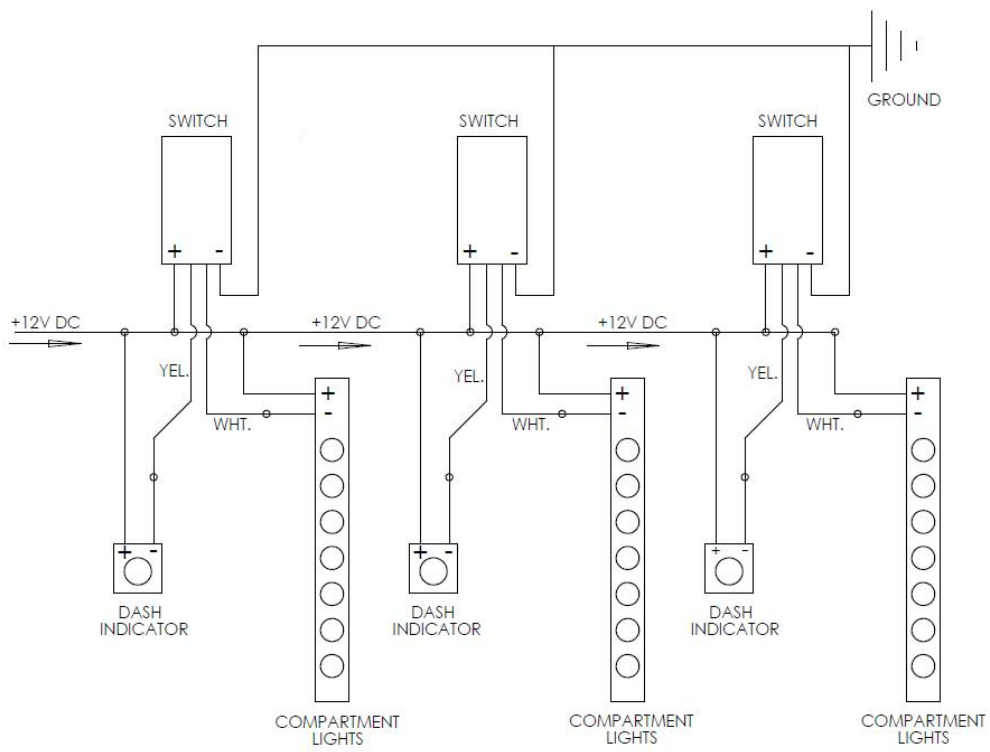
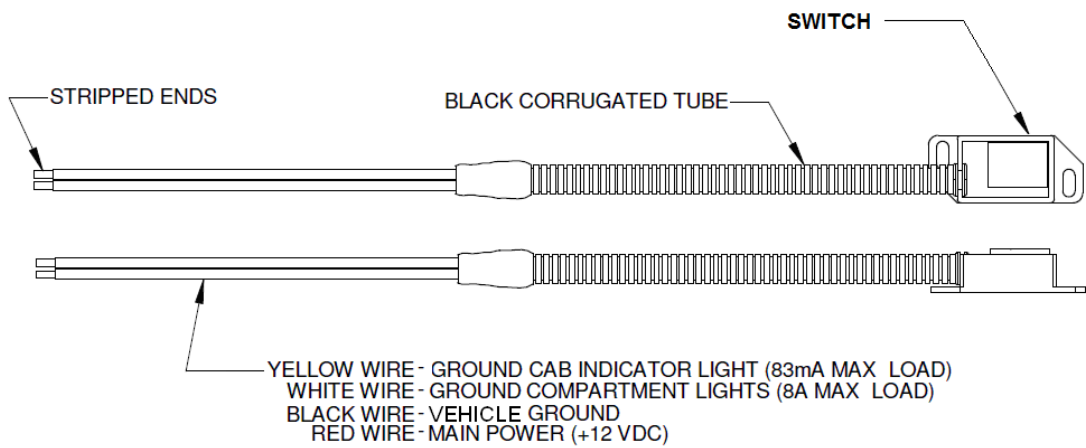
If your roll up door kit includes the door ajar switch and LED light tubes, now is the time to connect them to your vehicles power supply. Be sure not to reverse the polarity on the LEDs or they could burn out. Refer to Figs. 18, 19 and 20 for the particulars of the door ajar switch.

It is strongly recommended to use split sheathing (not supplied) to cover any exposed wiring, especially when routing it through cutouts in the compartment walls of the vehicle. Unlatch and raise and lower the door several times to check the functionality of the compartment lights and the switch.



***Fig. 18 – Door ajar switch locations***

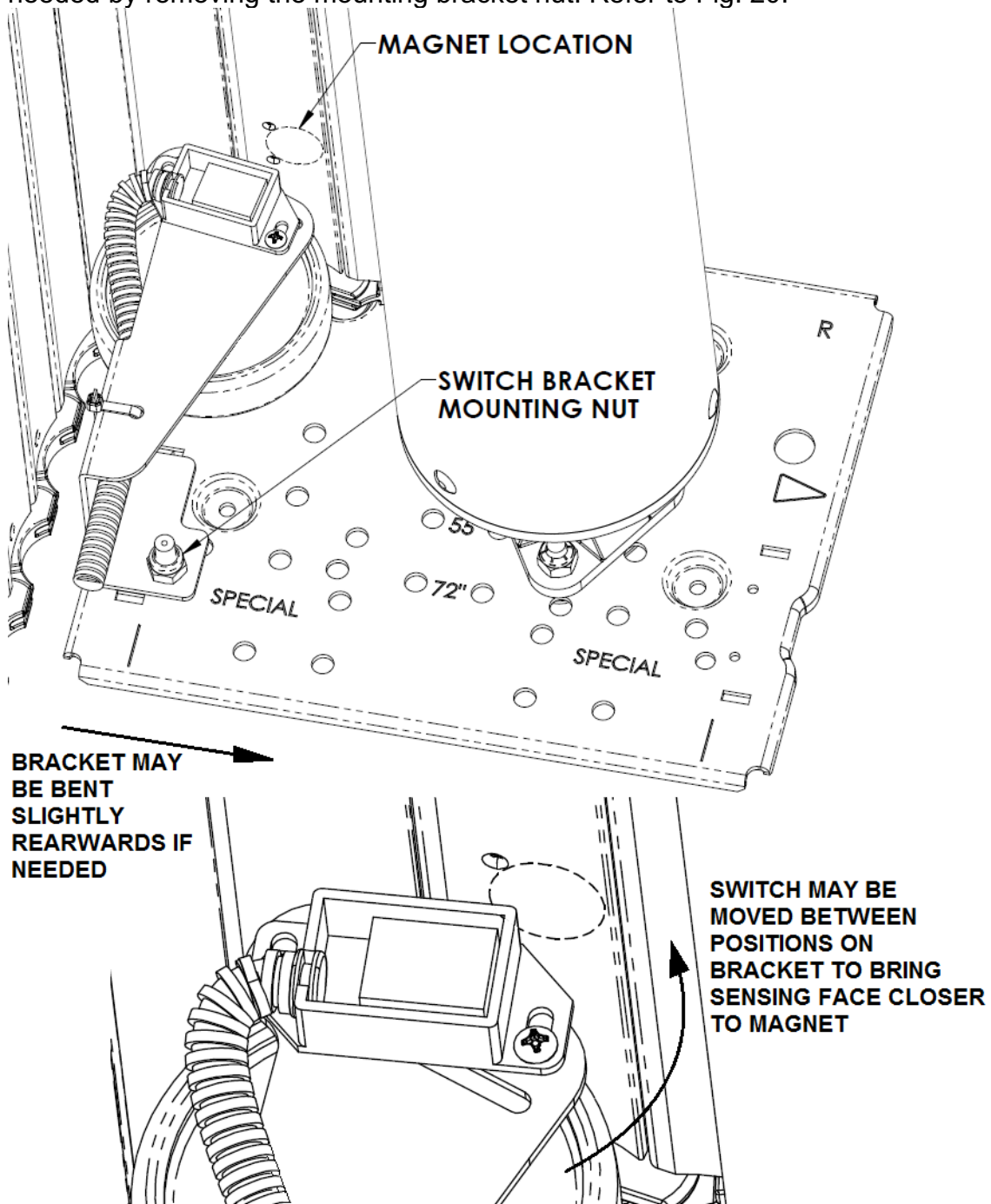
(Continued →)



**Fig. 19– Door ajar switch wiring**

(Continued →)

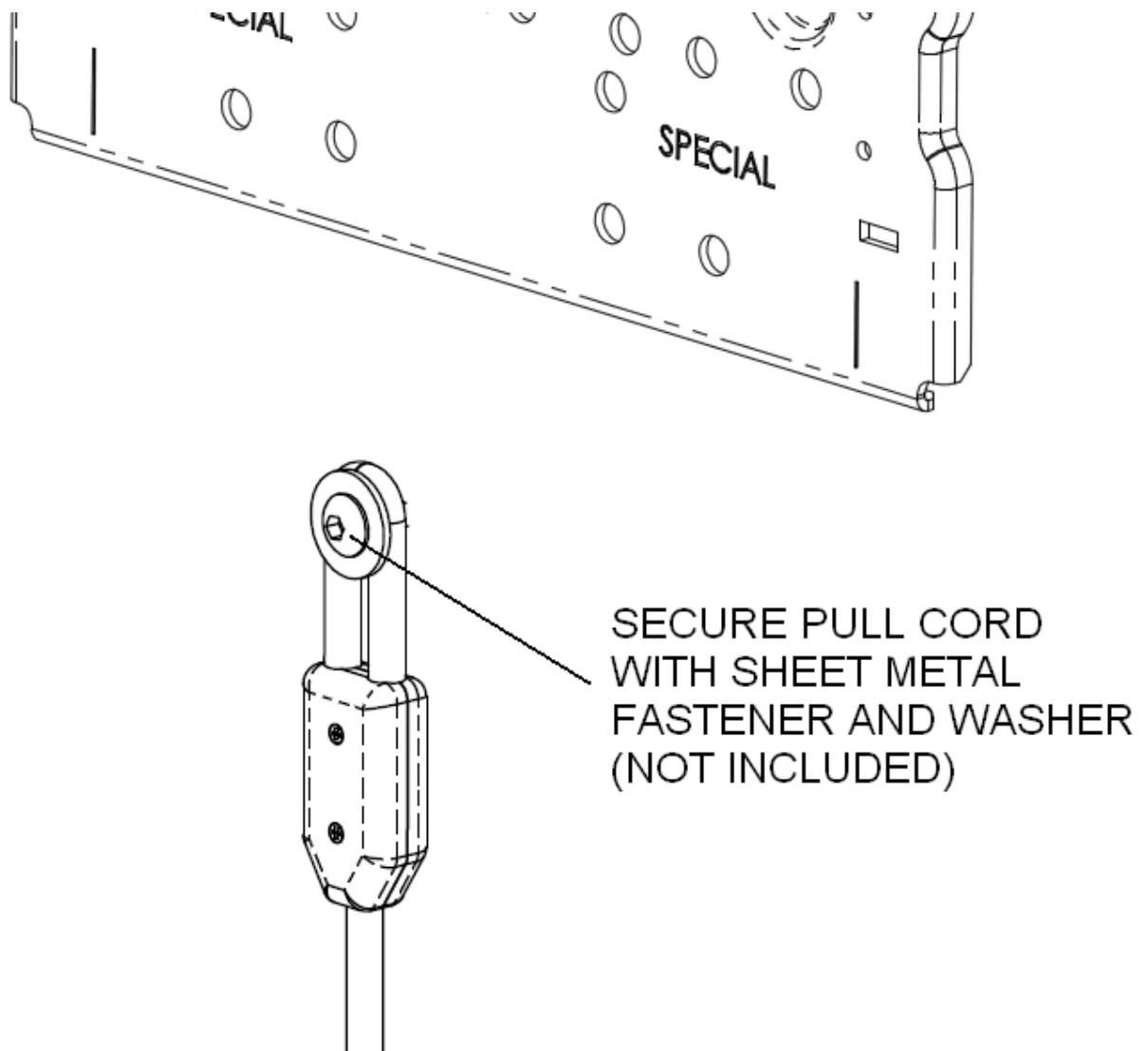
The door ajar switch is activated by a magnet that is in alignment with the switch when the door is closed and latched. For top mounted switches, the magnets location is at the top of the curtain and can be seen by the two dimples in the back of one of the last aluminum laths in the door. When properly positioned, the magnet should be above and slightly behind the door ajar switch sensing face. The switch and bracket may be taken down and adjusted slightly if needed by removing the mounting bracket nut. Refer to Fig. 20.



**Fig. 20– Door ajar switch adjustment**

## **Pull Cord**

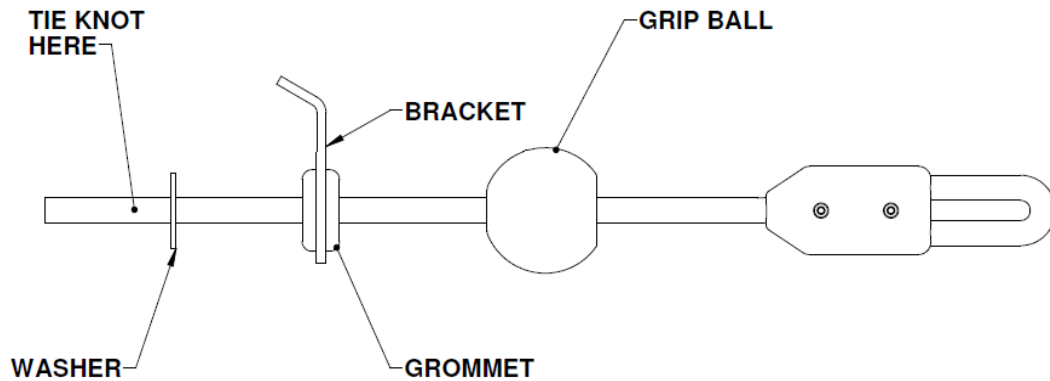
If your roll up door includes a pull cord, the looped and clamped end of the cord should be mounted to the compartment side wall using a screw or bolt and suitably sized washer (not provided) just underneath the middle of the bottom edge of the roller tube mounting plate as shown in Fig. 21.



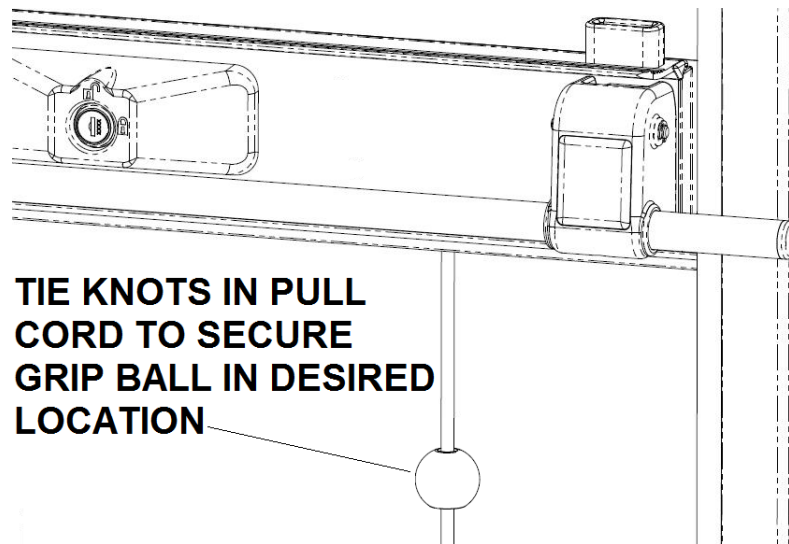
***Fig. 21 – Pull cord installation***

(Continued →)

Slide the ball knob onto the pull cord with the large opening in the knob facing the looped and clamped end (See Fig. 22). The length of the cord should be established with a knot behind the mounting bracket on the back of the handlebar so that when the door is closed and latched, the cord is held almost taut. Before tying this knot, a couple of knots should be placed behind the large counterbore in the grip ball so that when the door is raised and the pull cord is looped in a “U” shape, the ball is located on the side of the loop that will allow it to be used to pull the door down. The large counterbore in the pull knob should be pulled down over the locating knots in the rope to secure it. See Fig 23.



**Fig. 22 - Pull cord installation in bracket**



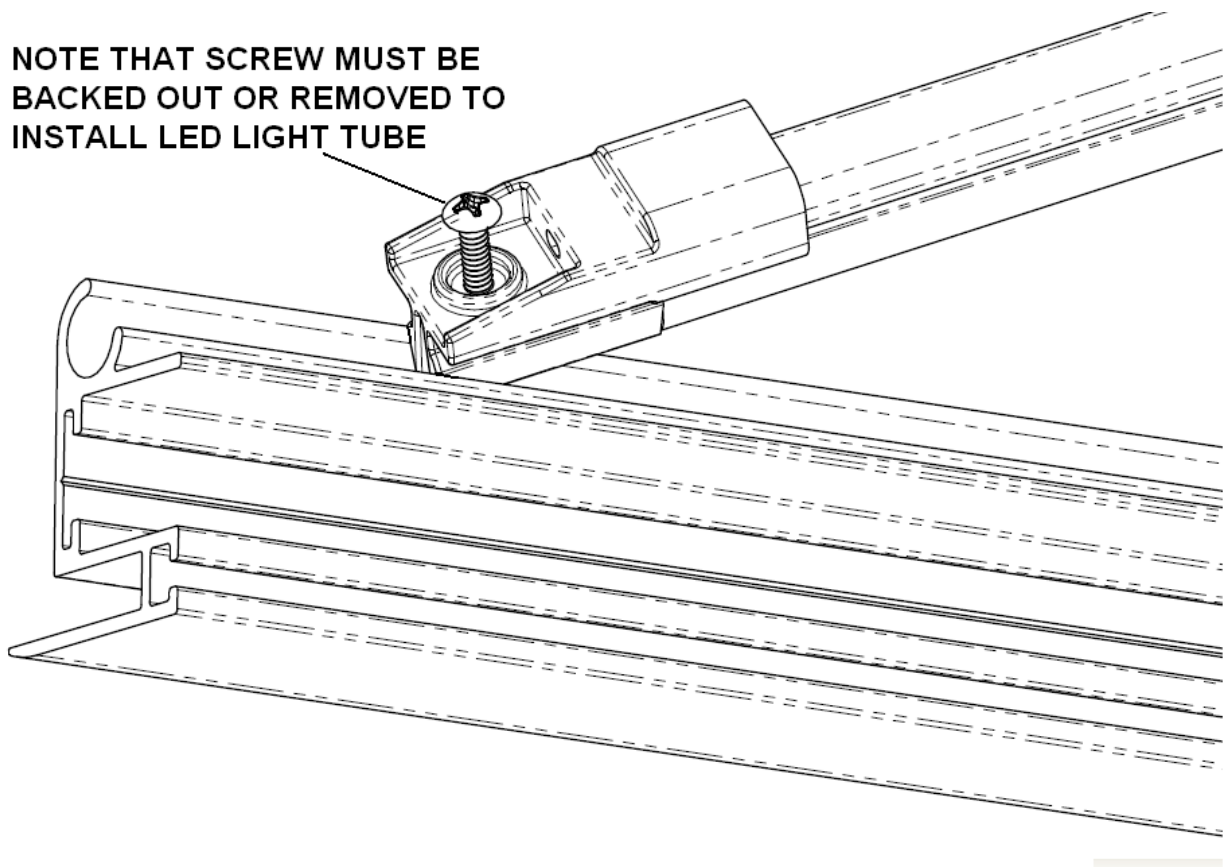
**Fig. 23- Pull cord installation (knob height)**

(Continued →)



## **10mm LED Compartment Lights**

For 10mm LED snap in light tubes, the easiest way to install them is to start the molded plastic end cap into the channel by snapping it in at an angle as shown in figure 24. Placing the palm against the outside face of the guide channel, the rest of the light tube may now be progressively snapped in using finger pressure. Snug the screws down into their bosses to secure the lights permanently.



***Fig. 24 – LED light tube installation***

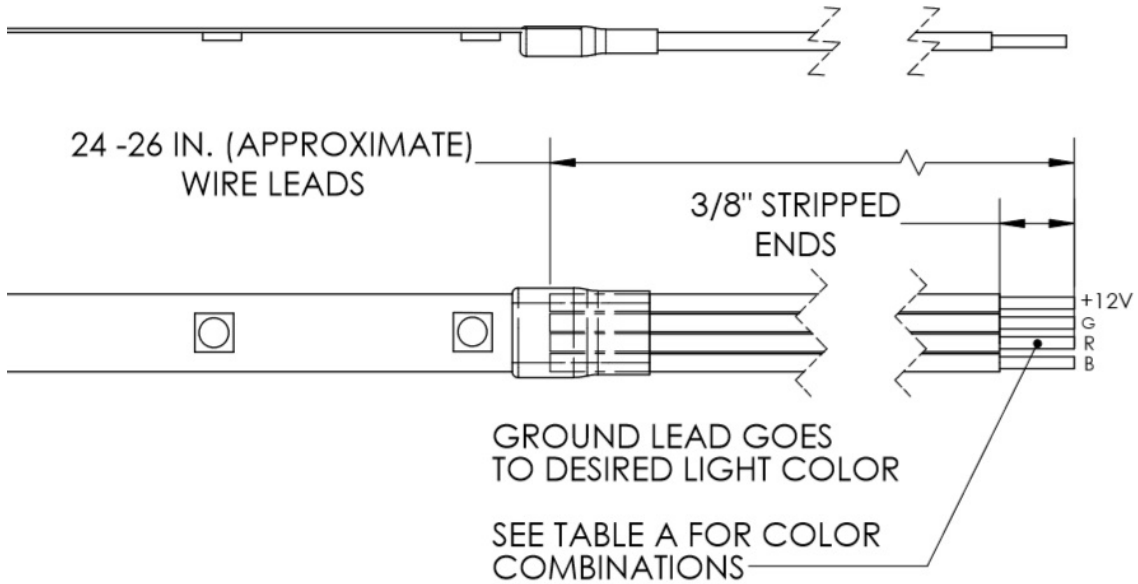
To remove the light tube in the unlikely event that a replacement is needed, simply back the screws out as shown, and using a large, flat bladed screwdriver tip underneath the edge of the molded end cap, pry one end of the tube free, then pull the rest of the tube out by hand, *taking care to avoid injury by banging against any compartment contents or shelving.*

(Continued →)

For RGB light strips, see Fig. 25 for wiring / color combos.

WIRE COMBINATION	LIGHT COLOR
RED + GREEN	YELLOW
RED + BLUE	MAGENTA
BLUE + GREEN	CYAN
RED + BLUE + GREEN	WHITE

**TABLE A**

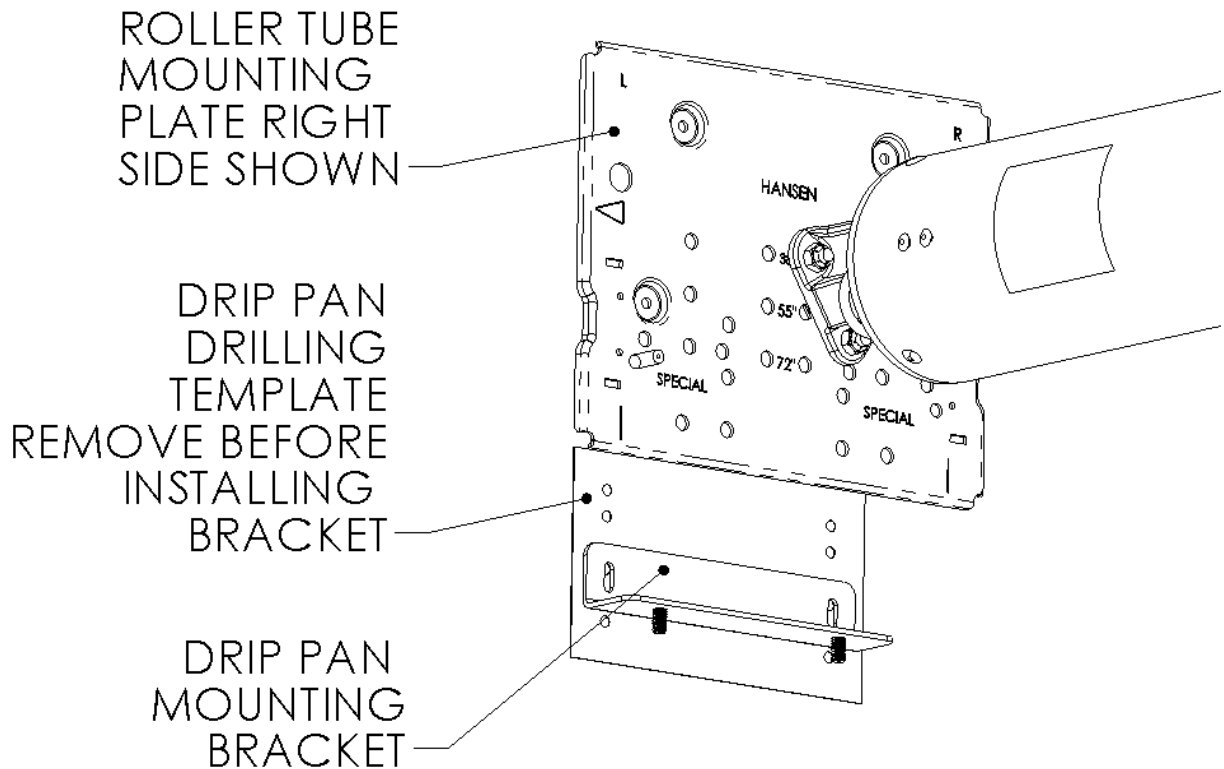


**Fig. 25 – RGB multi color light strips**

(Continued →)

## Drip Pan

For the optional drip pan, a printable drilling guide is located in the Appendix and should be aligned to each mounting plate as shown in Fig. 26 to locate the holes for the drip pan bracket. Be sure to check the dimensions provided for scale on the templates and the printers scaling factor when printing them out. For door heights that fall in between those listed on the drilling guide, discretion may be used to mount the drip pan a little closer to the curtain roll if so desired. It is not advisable to leave less than 0.50 in. of clearance between the rolled up curtains final maximum diameter and the drip pan. Secure the drip pan brackets to the compartment walls with the PEM studs facing down as shown. Use 3/16ths fasteners (not provided) suitable for the thickness of the material in the compartment wall. Using the cap nuts and lock washers supplied in the kit, secure the drip pan to the brackets and check again for clearance with the curtain roll



**Fig. 26 – Drip pan installation**

(Continued →)

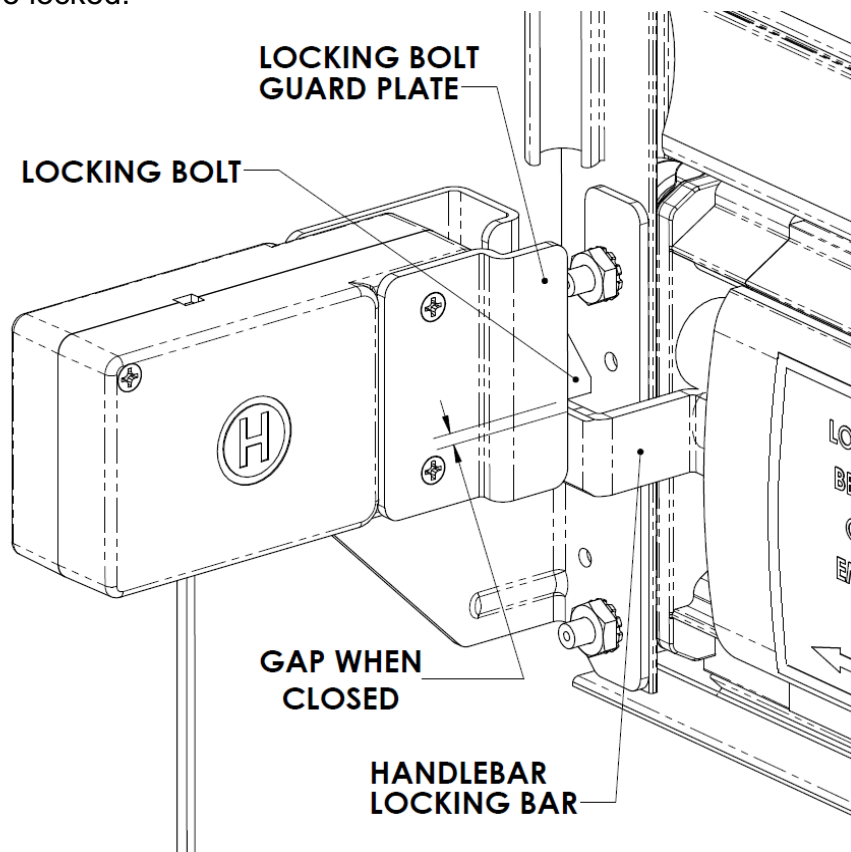
## **Electric Locking**

The electric locking units are two wire solenoids. A positive to positive current flow will retract the locking bolt. Reversing the polarity will extend it.

It is critically important to install the guide channels so they are resting against the floor of the compartment (or the optional bottom sill plate) and that the keepers keep the bottom rubber door seal compressed fully. When the door is closed and the bar is latched, there must be a gap of no less than 1/16" between the locking bars of the solenoids, and the handlebar locking bar. **This gap is critical as it allows the use of the manual key override and emergency inside release.**

When installation is complete, test functionality of key override by extending the E-lock solenoid bolts (this can be done manually if necessary) with the door closed and latched. The key function is spring tensioned and the key must be turned and held in the unlocked position while the handlebar is raised. The key must be returned to the locked position to be removed.

Note that the key is strictly used as an override feature when used in conjunction with electric locking units. The solenoids must be extended for the door to be locked.



**Fig. 27 – E-lock functionality**

(Continued →)

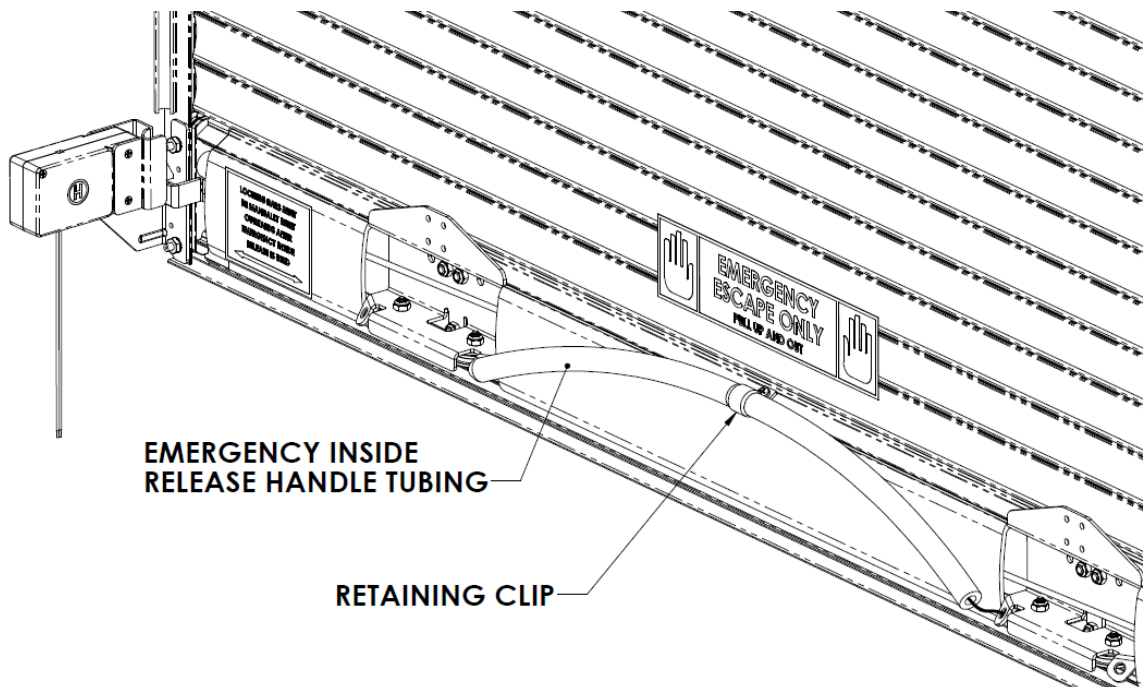
## Emergency Inside Release

The emergency inside release option is a pull cable with a rubber handle in the center. Release the handle from the retaining clip and pull upward and to the rear to unlock, unlatch, and raise the door slightly. The vehicle may then be exited by placing your hands underneath the bottom of the door and raising it fully.

# **\*\*WARNING\*\***

**It is critical to fully test the operation of the emergency inside release mechanism for correct functionality with the door in the closed, latched, and locked position.**

**DO NOT ATTEMPT TO PERFORM THIS FUNCTION TEST WITHOUT SOMEONE REMAINING OUTSIDE THE VEHICLE TO ASSIST WITH ESCAPE FROM THE COMPARTMENT IF NECESSARY.**

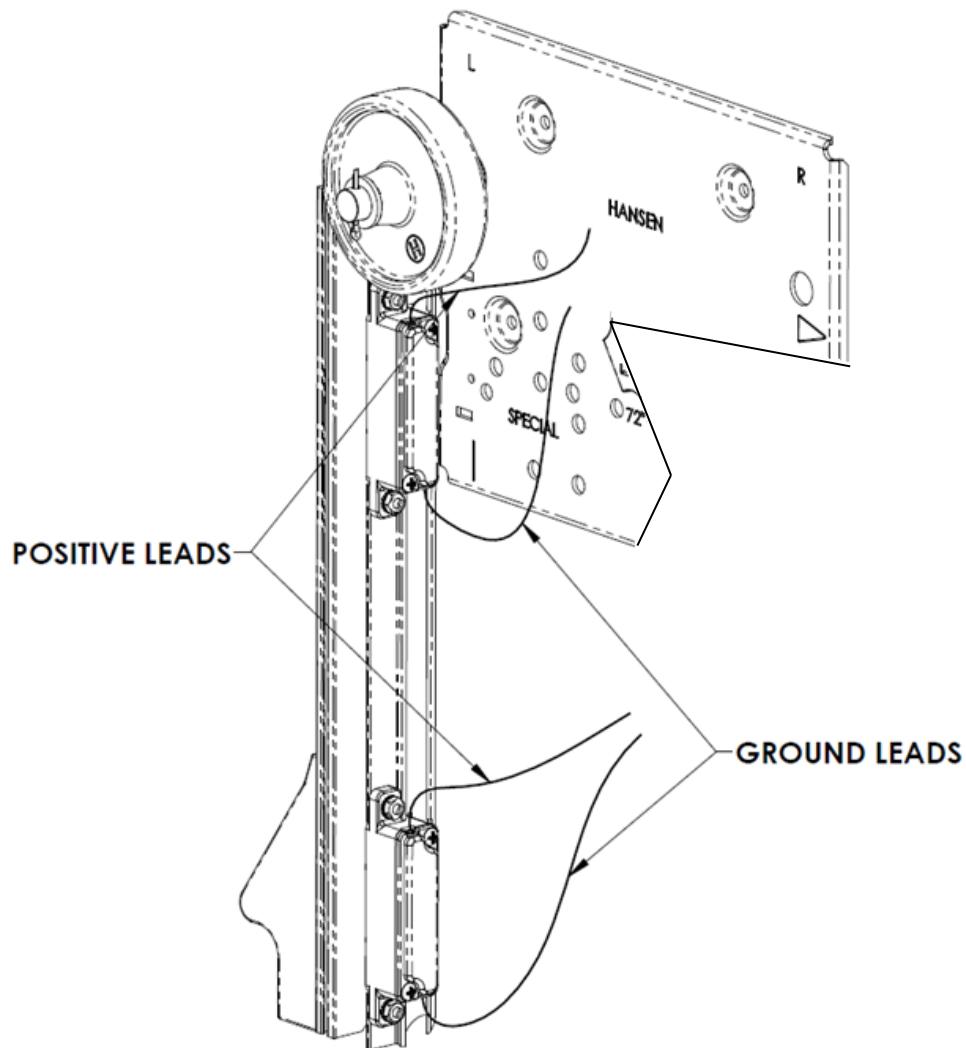


***Fig. 28 – Emergency inside release handle location***

## **Lit Handlebar**

The contact units for the lit handlebar are located on the back side of one of the guide channels (left or right hand side as specified on sales order). The positive (red) leads should be coming out of the top of both contact units, and the ground (black) leads out the bottom of each (see Fig. 29) These should be connected to the vehicles positive power and ground wires.

Test the functionality of the backlit handlebar by opening and closing the door. The light should come on when the handlebar is fully raised and the rubber bumpers stopped against the drip rail, and also when the door is fully closed and latched.



***Fig. 29 – Lit handlebar contact units***

(Continued →)

## **Cleaning And Maintenance Of Hansen Roll Up Doors**

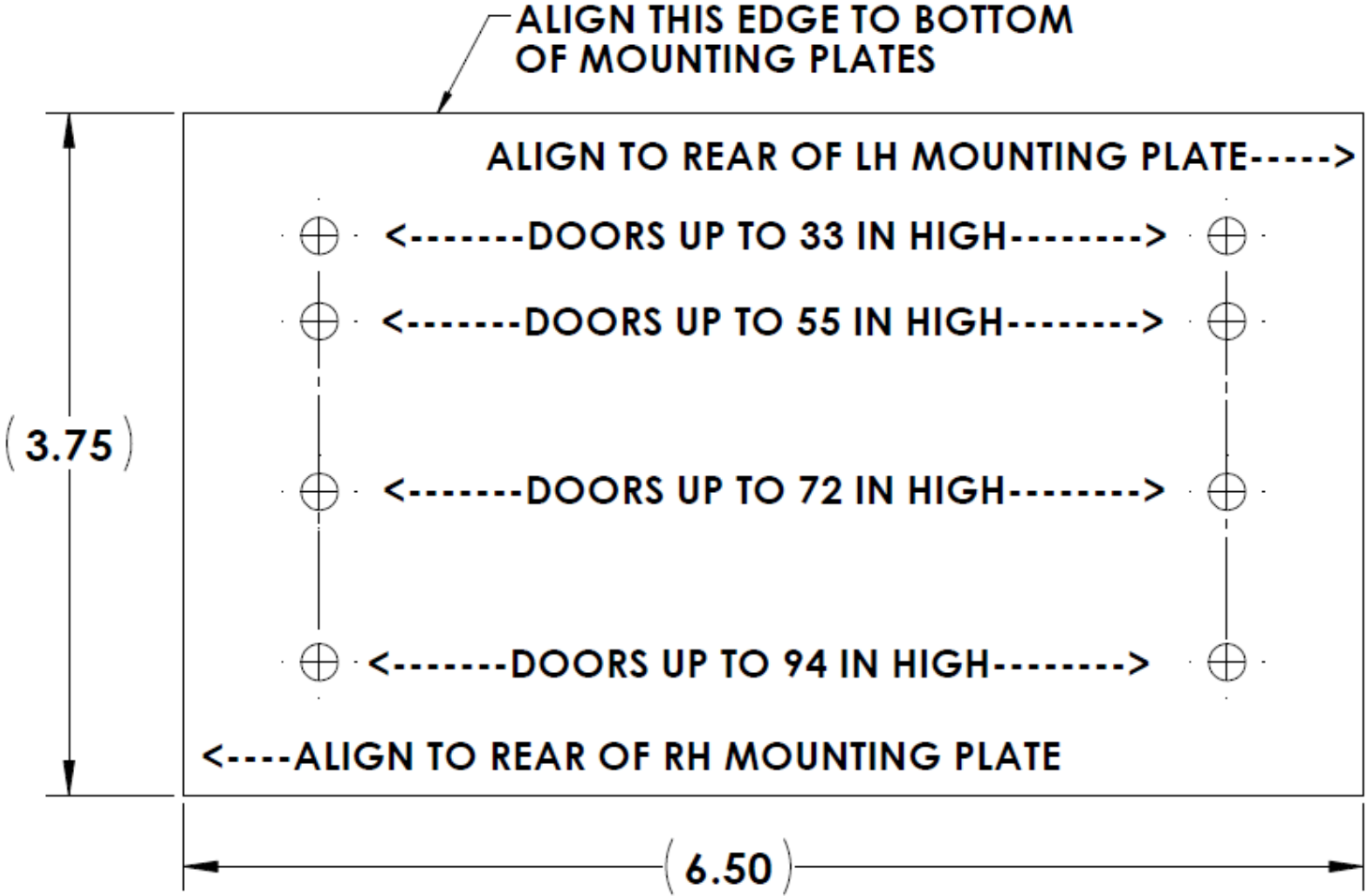
Although the aluminum components of your door are hard anodized for protection from the elements, it is important to periodically clean your roll up door assembly, not only to wash away acids or salts from local road treatment and air quality, but to remove grime and road dust that can accumulate and affect smooth operation and increase wear on moving parts. In addition, grit and dust accumulation on the exterior surfaces of the door can lead to scratching or dulling of applied paint and decals on the curtain exterior.

Exterior surfaces of the curtain should be cleaned with a mild detergent solution. It is not recommended to use pressure washing devices as these generate forces that can damage the soft seals around the edges of the curtain and the clear seals between individual curtain laths. The tracks in the guide rails should be kept clean and free of grit and salts. Use the same detergent solution and a clean cotton cloth or soft nylon bristle brush to thoroughly clean the tracks in the guide channels. In case of heavy contamination by dirt or grit, it may be necessary to remove the guide channels and clean the wheel carriers on the latch lath and the individual end caps of each lath in the curtain. Frequent inspection and cleaning (when necessary) will minimize the need for this and extend the life of your roll up door.

If lubrication of the tracks is desired, it is recommended to use only a drying type lubricant such as graphite or silicone spray. Use of grease or oils will serve only as a magnet for grit and will eventually make operation more difficult and accelerate wear.

Check frequently to make sure the handle bar is operating smoothly and locks positively underneath the handle bar keepers, and that the keepers remain tightly riveted to the guide channels.

**APPENDIX**



*Fig. 30 – Drip pan drilling guide*