

ITEM NO.	PART NUMBER	DESCRIPTION	QTY
1	WH61-17221-63	ASM NON-LOCKING SLAM LATCH HANDLE	1
2	PMISC257	LOCKIN/LOCKOUT KIT	1

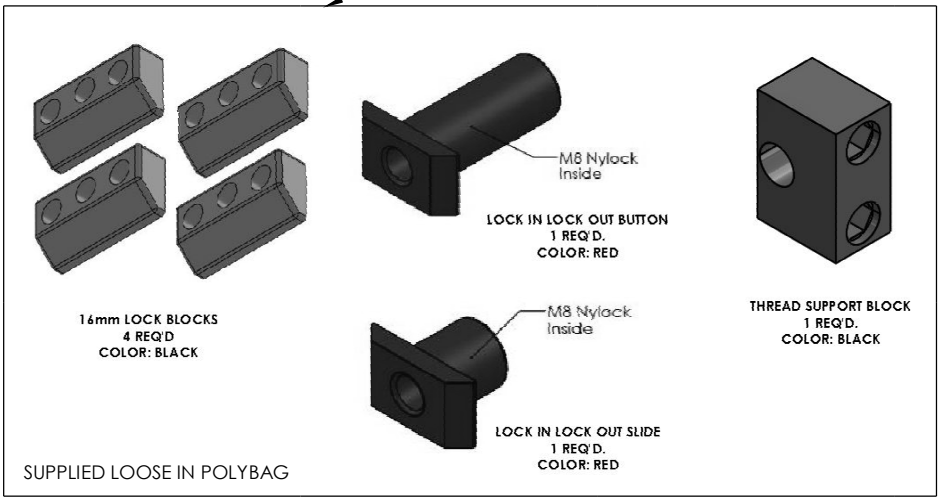
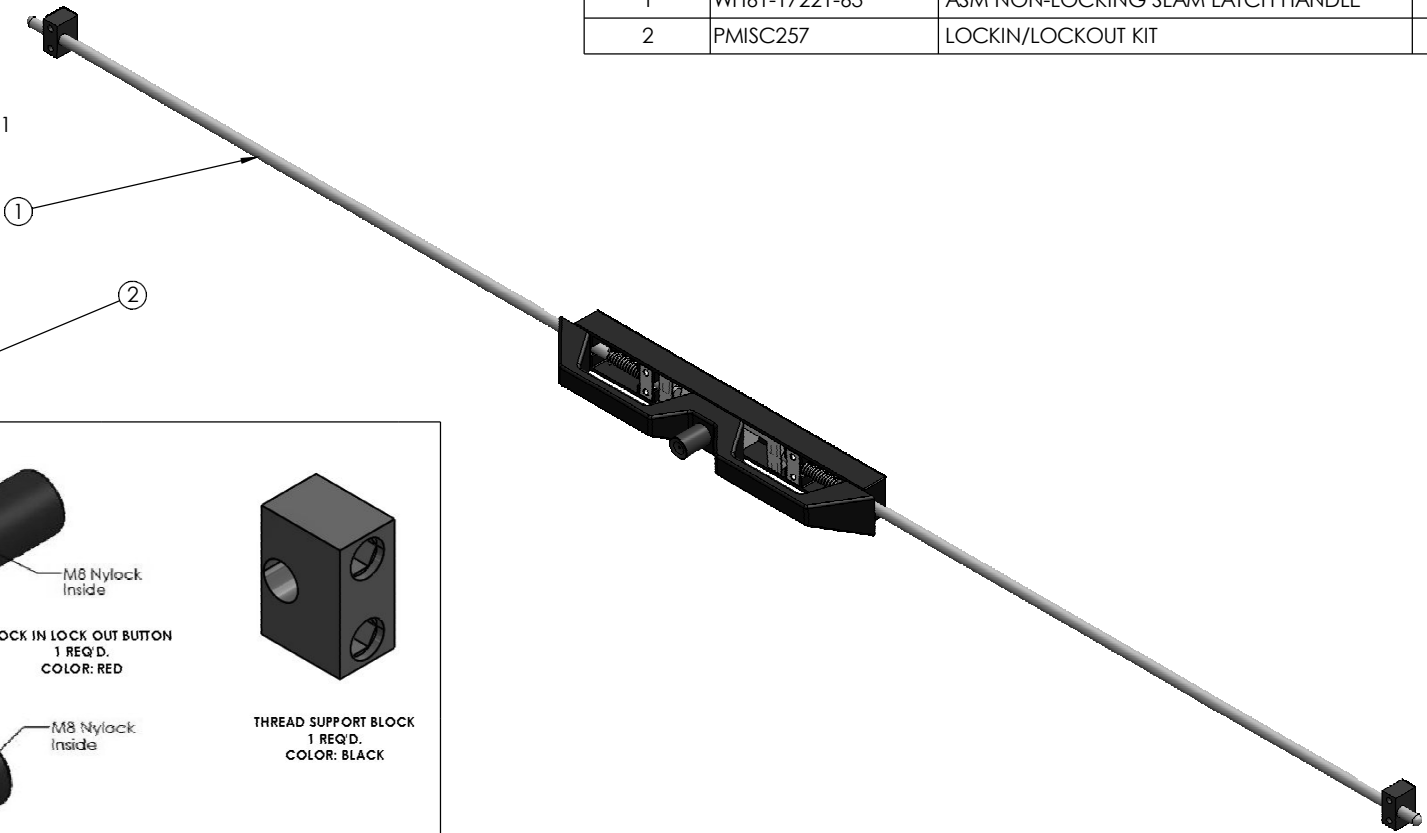
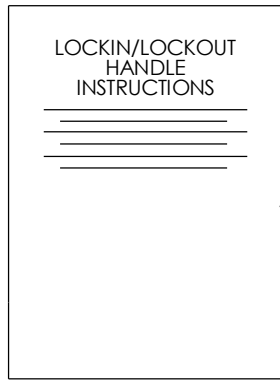

NOTES:
1. FOR LOCKIN/LOCKOUT HANDLE INSTRUCTIONS REFERENCE DOCUMENT INST00015.

Weight	SHEET 1 OF 1
NA	SCALE: 1:4
VOL.	TOLERANCES (UNLESS OTHERWISE SPECIFIED)
NA	1 PLCS ± .5
	2 PLCS ± .25
	HOLES ± .20
	ANGLES ± .5°
KEY CRITICAL TO FUNCTION	R&D NUMBER: NA

HANSEN INTERNATIONAL, INC.
LEXINGTON, S. CAROLINA

PROPRIETARY NOTICE:
THIS DRAWING IS EXCLUSIVELY THE PROPERTY OF HANSEN INTERNATIONAL INC. AND SHALL NOT BE COPIED OR PASSED ON TO A THIRD PARTY WITHOUT OUR PRIOR WRITTEN APPROVAL. WE WILL RETAIN ALL RIGHTS FOR PATENT ISSUE OR REGISTRATION OF DESIGN.

GEOMETRIC DIMENSIONING & TOLERANCING PER ASME Y14.100-2004

REV	ERN/ECN NO.	CHANGED BY	DATE CHANGED	APPROVED BY	DATE APPROVED
-	ECR18204	MTA	9/7/2018	PJC	9/17/2018
MATERIAL: NA					
FINISH: NA					
DESCRIPTION: LOCK IN LOCK OUT HANDLE KIT					
SIZE	Part Number: WH61-17221-63KT				
B					