

DETAIL A
SCALE 1 : 2
(COVER REMOVED)

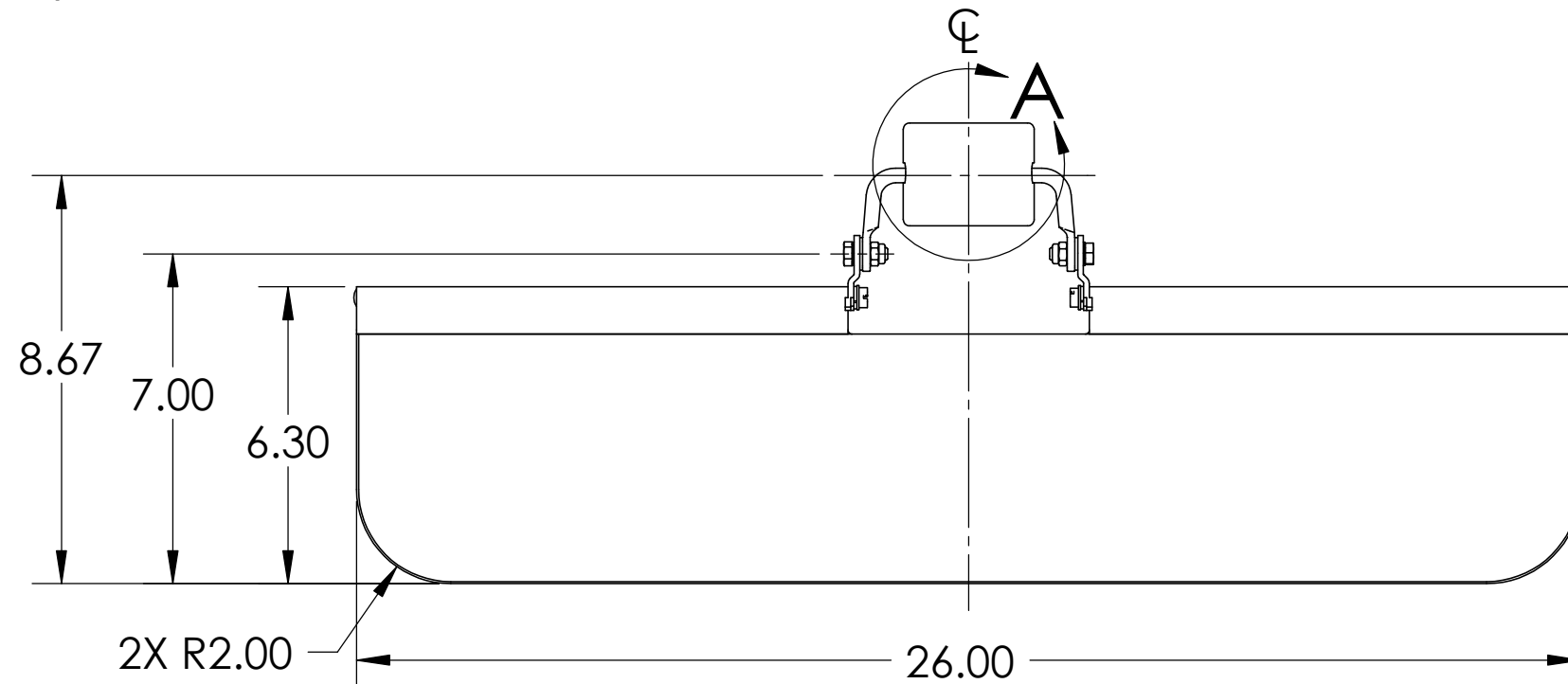

NOTE(s):

1. ASSEMBLY SHALL MEET FMVSS302.
2. LEXAN: 3/16" NOMINAL GRAY GP LITE EXTRUDED SHEET.
3. FINISH: BRACKETS: BLACK E-COAT
HINGES: BLACK E-COAT
ALTERNATE FINISH FOR HINGES: ANODIZE BLACK PER ARCHITECTUAL CLASS 2 (AAM10C22A31)
4. DIMENSIONS ARE FOR REFERENCE ONLY.
5. ASSEMBLY IS SYMMETRICAL ABOUT C.
6. EDGE CONDITION LEXAN PERIMETER TO REMOVE SHARP EDGES.

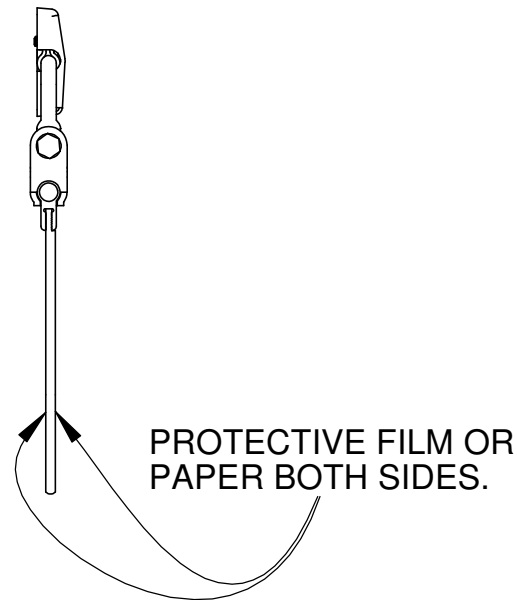
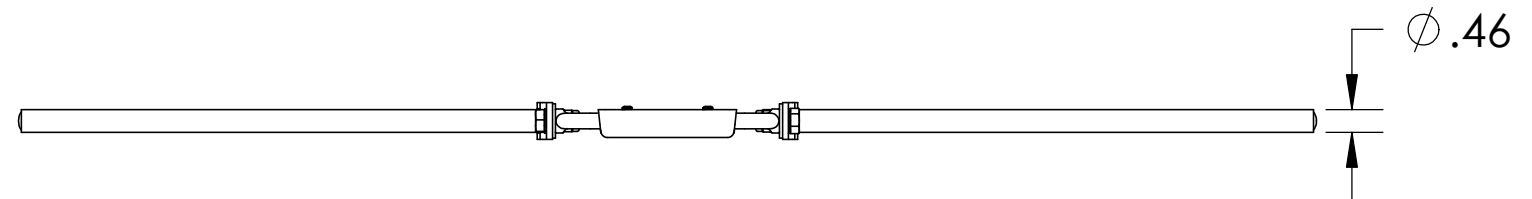
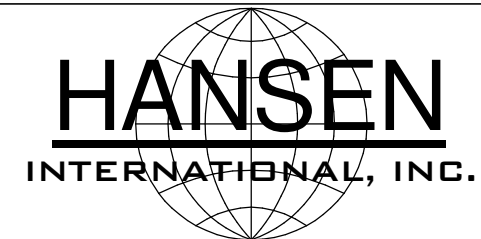

DESCRIPTION: ASM., SUN VISOR-LEXAN 7" x 26"	Weight 2.1 LBS
Part Number: SV2430726XCM	REV -

PROPRIETARY NOTICE: THIS DRAWING IS EXCLUSIVELY THE PROPERTY OF HANSEN INTERNATIONAL INC. AND SHALL NOT BE COPIED OR PASSED ON TO A THIRD PARTY WITHOUT OUR PRIOR WRITTEN APPROVAL. WE WILL RETAIN ALL RIGHTS FOR PATENT ISSUE OR REGISTRATION OF DESIGN.
©2018 Hansen International, Inc.