

DETAIL A

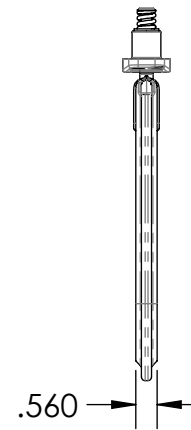

NOTES:

1. MATERIAL:
 1. MOUNTING BRACKET AND ROD: MILD STEEL ROD, CAST ZINC BRACKET
 2. VISOR: FLAME BONDED VINYL, FOAM, PAPERBOARD TRILAMINATE.
2. FINISH:
 1. MOUNTING BRACKET AND ROD: BLACK POWDER COAT.
 2. VINYL: SLATE GREY.
 3. SEWING THREAD: MEDIUM GREY.
3. DIMENSIONS ARE FOR REFERENCE ONLY.

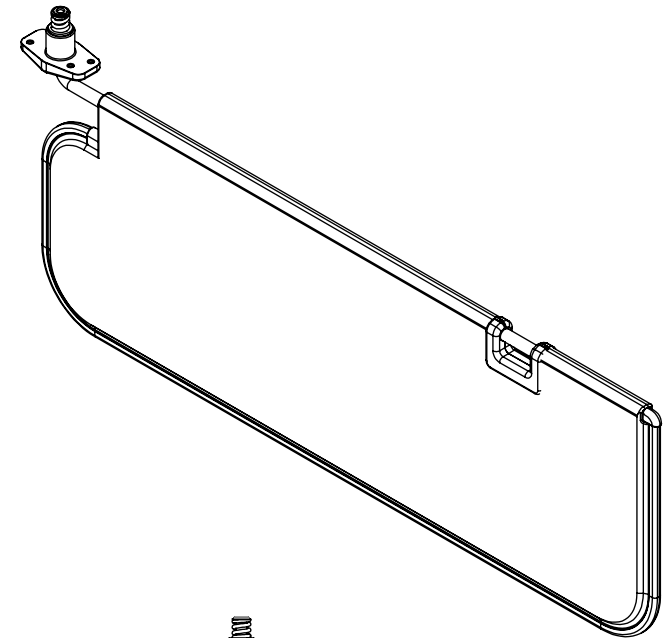
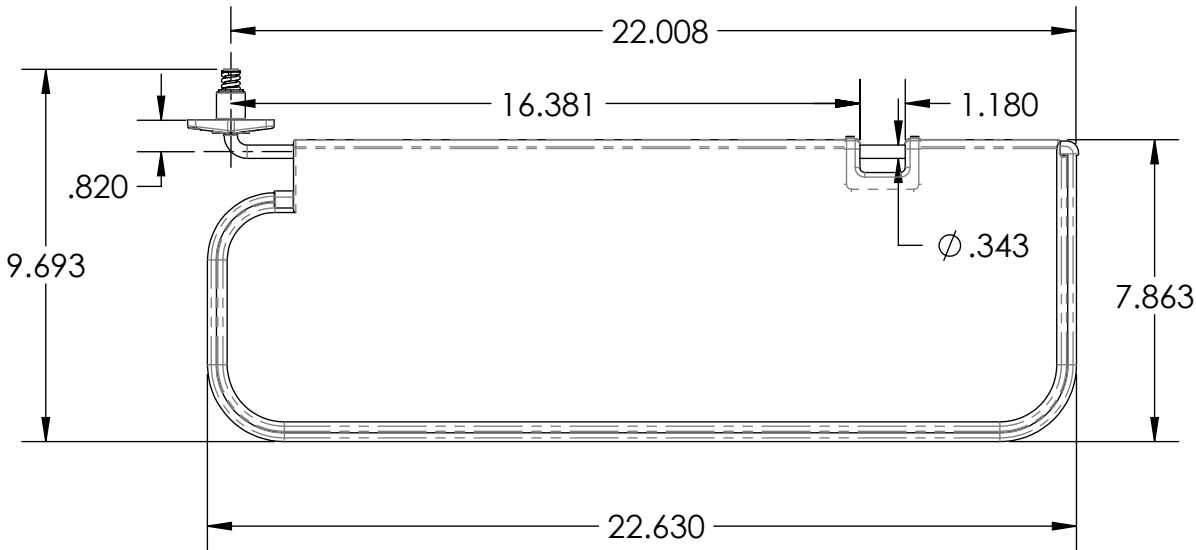
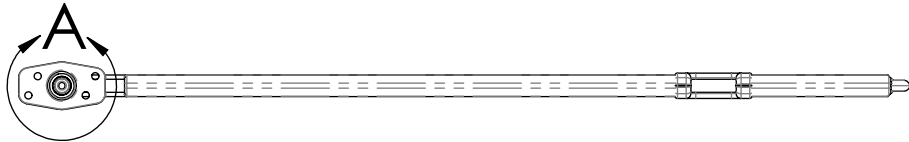

DESCRIPTION:	Weight
ASM., SUN VISOR - LEFT 7.9 x 22.63 PLAIN	2.11 LBS
Part Number:	REV
SV1600823LHSG01	-

PROPRIETARY NOTICE: THIS DRAWING IS EXCLUSIVELY THE PROPERTY OF HANSEN INTERNATIONAL INC. AND SHALL NOT BE COPIED OR PASSED ON TO A THIRD PARTY WITHOUT OUR PRIOR WRITTEN APPROVAL. WE WILL RETAIN ALL RIGHTS FOR PATENT ISSUE OR REGISTRATION OF DESIGN.

©2020 Hansen International, Inc.