

DETAIL A

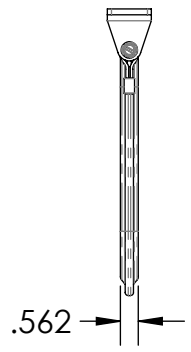

- NOTES:
- MATERIAL:
 - BRACKETS AND HINGE: ALUMINUM HINGE, MILD STEEL BRACKETS
 - VISOR: FLAME BONDED VINYL, FOAM, PAPERBOARD TRILAMINATE.
 - FINISH:
 - BRACKETS AND HINGE: BLACK E-COAT.
 - VINYL: GAUCHO BLACK.
 - SEWING: BLACK.
 - DIMENSIONS ARE FOR REFERENCE ONLY.

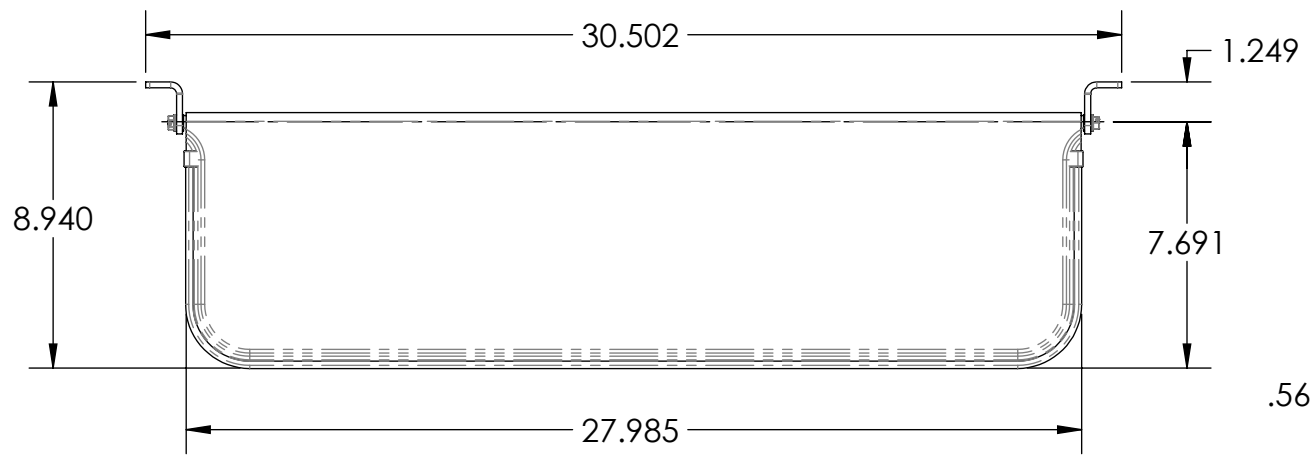
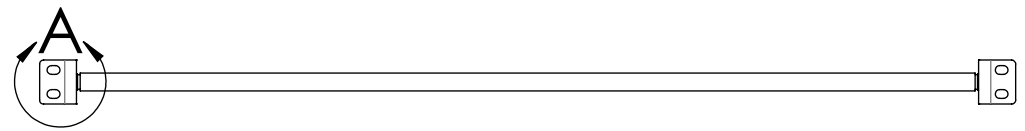
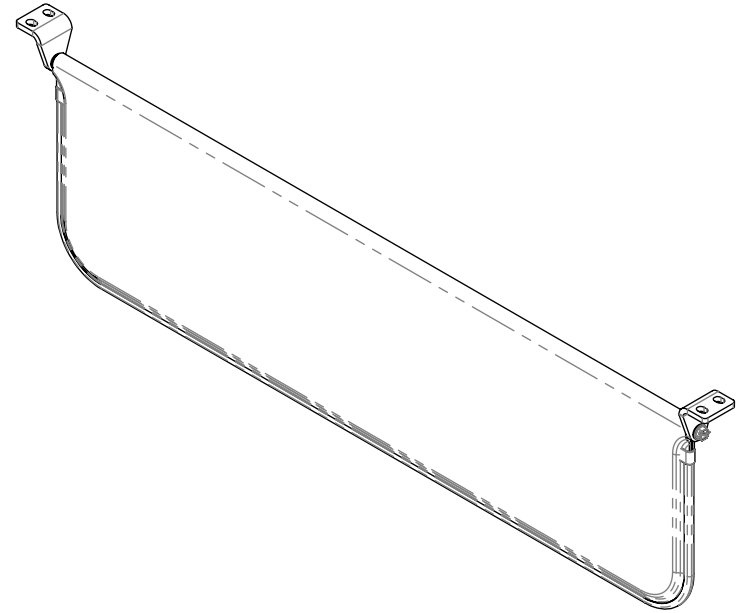

DESCRIPTION:	Weight
ASSY., SUN VISOR 8 X 28 DM	3.4 LBS
Part Number:	REV
SV1390828BOT	-
<small>PROPRIETARY NOTICE: THIS DRAWING IS EXCLUSIVELY THE PROPERTY OF HANSEN INTERNATIONAL INC. AND SHALL NOT BE COPIED OR PASSED ON TO A THIRD PARTY WITHOUT OUR PRIOR WRITTEN APPROVAL. WE WILL RETAIN ALL RIGHTS FOR PATENT ISSUE OR REGISTRATION OF DESIGN.</small>	
<small>©2020 Hansen International, Inc.</small>	