

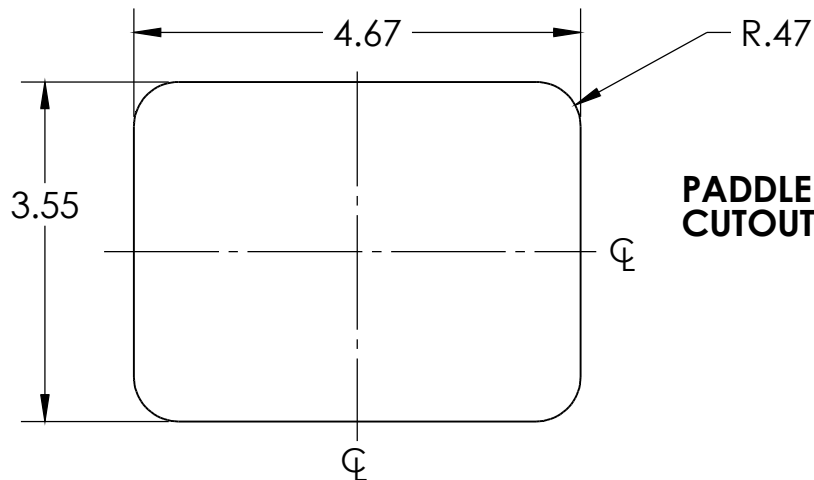

NOTES:

1. MATERIAL AND FINISH: CLEAR ZINC PLATED STEEL TRAY AND HANDLE. ALL OTHER COMPONENTS ARE ZINC PLATED OR STAINLESS STEEL.
2. = DENOTES DIMENSIONS THAT ARE EQUALLY SPACED ABOUT THE CENTERLINE.
3. DIMENSIONS ARE FOR REFERENCE ONLY.

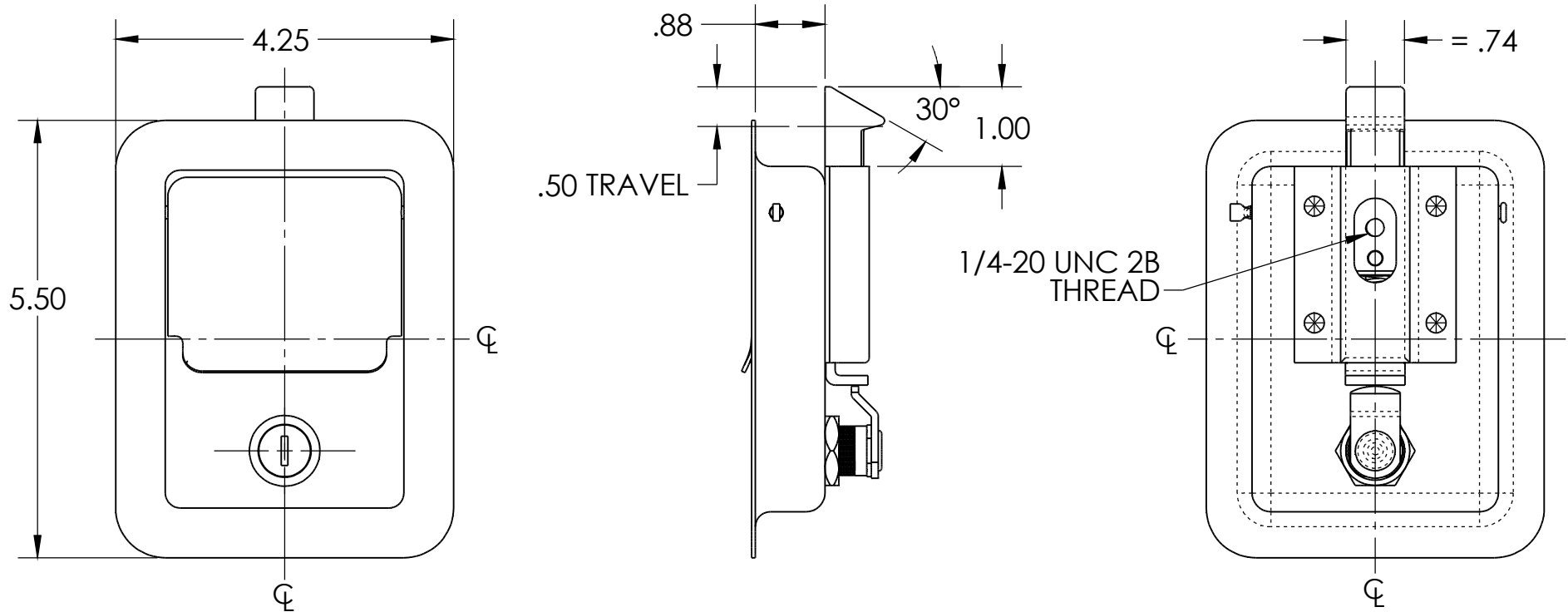

		
DESCRIPTION:	ASSEMBLY-1-DSL-ZN 30° LATCH	Weight 1.02 LBS
Part Number:	10X623X0XL	REV -
<small>PROPRIETARY NOTICE: THIS DRAWING IS EXCLUSIVELY THE PROPERTY OF HANSEN INTERNATIONAL INC. AND SHALL NOT BE COPIED OR PASSED ON TO A THIRD PARTY WITHOUT OUR PRIOR WRITTEN APPROVAL. WE WILL RETAIN ALL RIGHTS FOR PATENT ISSUE OR REGISTRATION OF DESIGN.</small>		
<small>©2018 Hansen International, Inc.</small>		