

NOTES:

1. MATERIAL AND FINISH: POLISHED STAINLESS STEEL TRAY WITH CHROME HANDLE. ALL OTHER COMPONENTS ARE ZINC PLATED OR STAINLESS STEEL.
2. = DENOTES DIMENSIONS THAT ARE EQUALLY SPACED ABOUT THE CENTERLINE OF THE PART.
3. RECOMMENDED FASTENER GRADE 5 NYLOCK NUTS, TORQUE TO 17 IN/LBS.
4. DIMENSIONS ARE FOR REFERENCE ONLY.

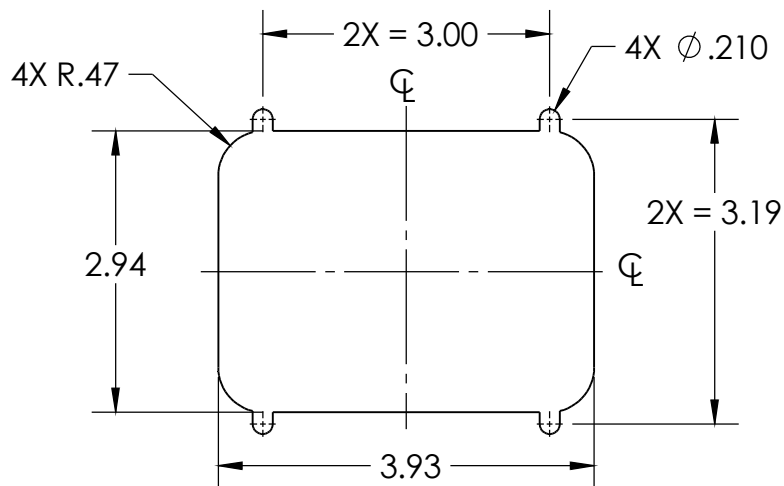

T-HANDLE CUTOUT

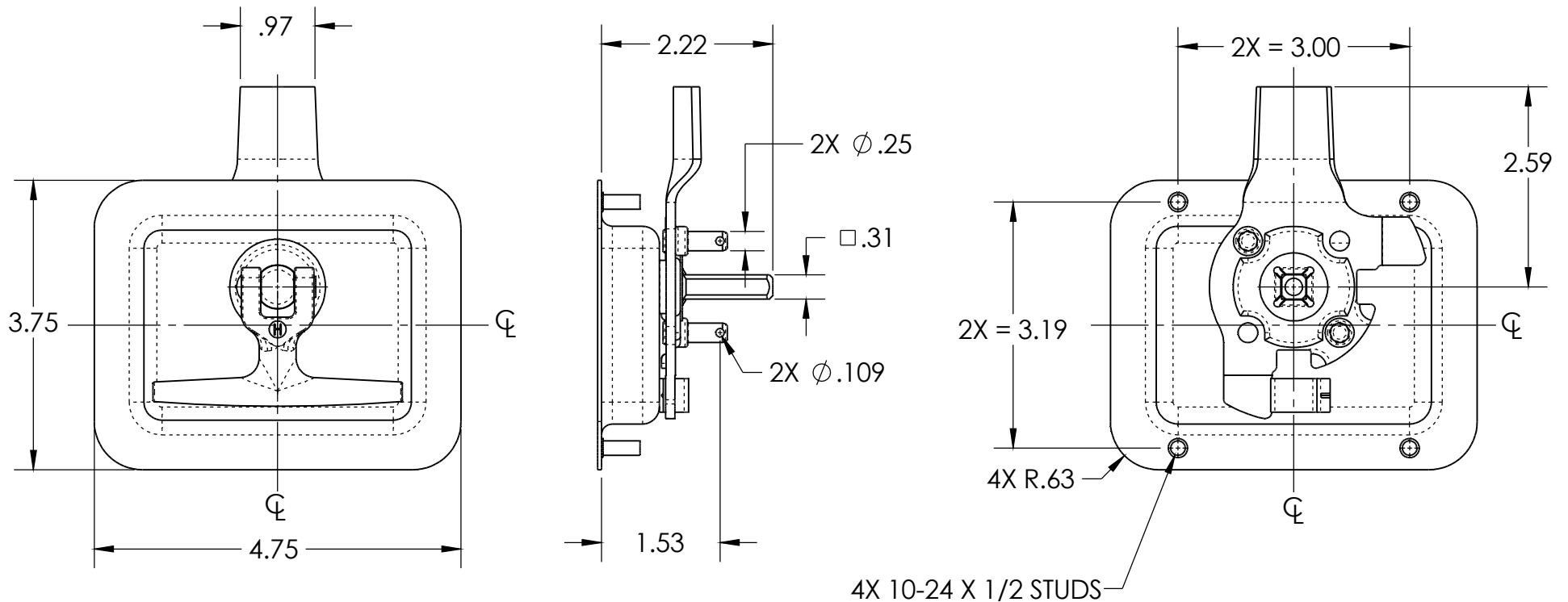

DESCRIPTION: ASSEMBLY-403-S SS REV STUDS BLIND MOUNT	Weight .92 LBS
Part Number: TS403SXLSPBBM	REV -

PROPRIETARY NOTICE: THIS DRAWING IS EXCLUSIVELY THE PROPERTY OF HANSEN INTERNATIONAL INC. AND SHALL NOT BE COPIED OR PASSED ON TO A THIRD PARTY WITHOUT OUR PRIOR WRITTEN APPROVAL. WE WILL RETAIN ALL RIGHTS FOR PATENT ISSUE OR REGISTRATION OF DESIGN.
©2018 Hansen International, Inc.