

T-HANDLE CUTOUT

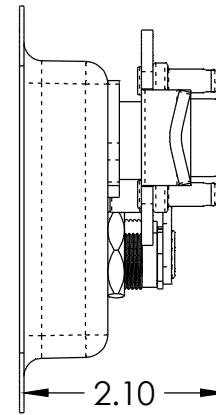

NOTES:

1. MATERIAL AND FINISH: STEEL TRAY AND HANDLE W/GALVANEAL FINSH.
2. DIMENSIONS ARE FOR REFERENCE ONLY.
3. = DENOTES DIMENSIONS THAT ARE EQUALLY SPACED ABOUT THE CENTERLINE.

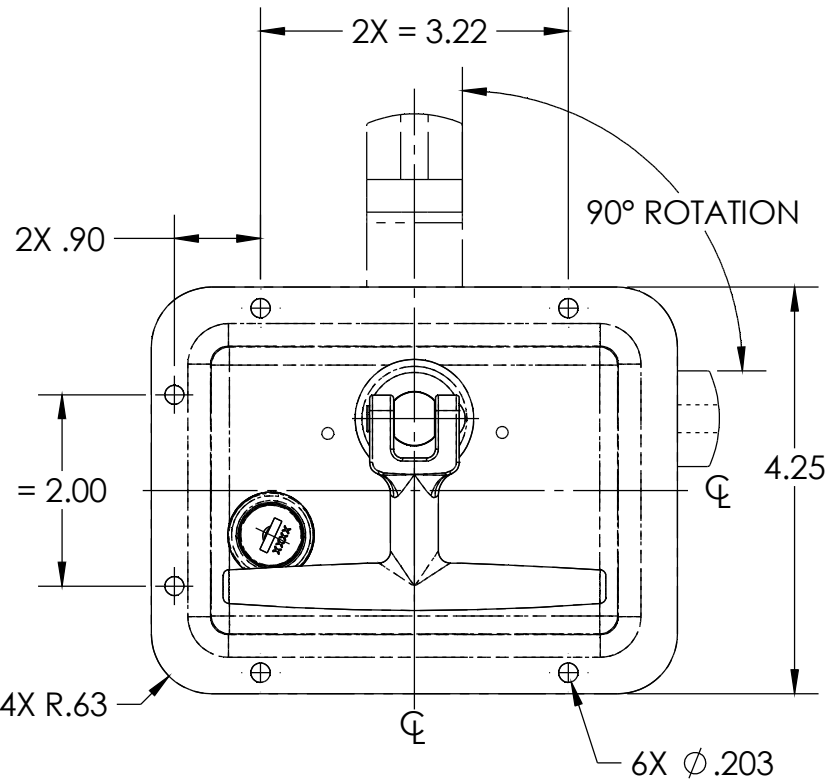

DESCRIPTION: ASSEMBLY - #3403-L LH GALVANEAL		Weight 1.17 LBS
Part Number: TS3403LLXGVKN		REV -
<small>PROPRIETARY NOTICE: THIS DRAWING IS EXCLUSIVELY THE PROPERTY OF HANSEN INTERNATIONAL INC. AND SHALL NOT BE COPIED OR PASSED ON TO A THIRD PARTY WITHOUT OUR PRIOR WRITTEN APPROVAL. WE WILL RETAIN ALL RIGHTS FOR PATENT ISSUE OR REGISTRATION OF DESIGN.</small> ©2018 Hansen International, Inc.		