

1.64 CAM MAX

1.25 CAM MIN

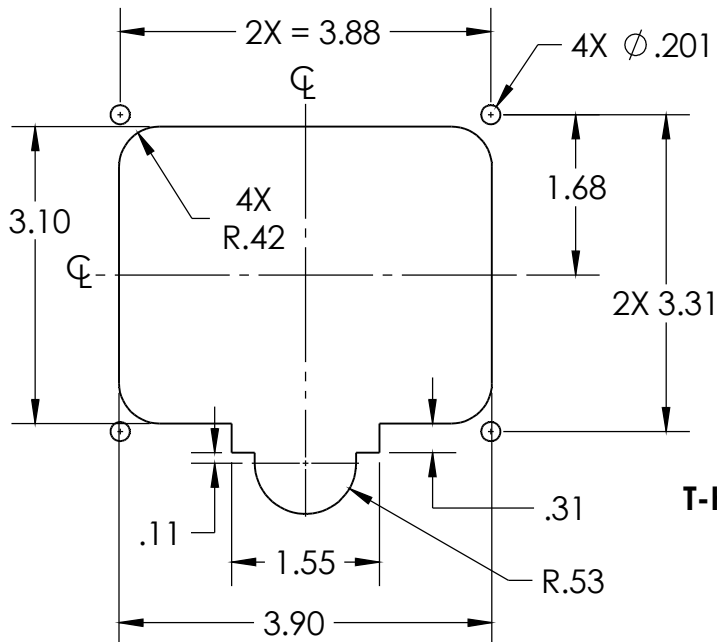
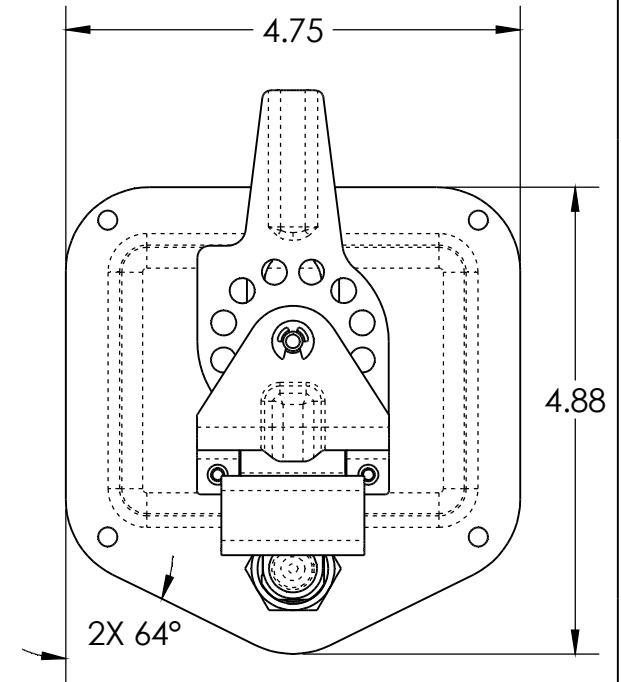
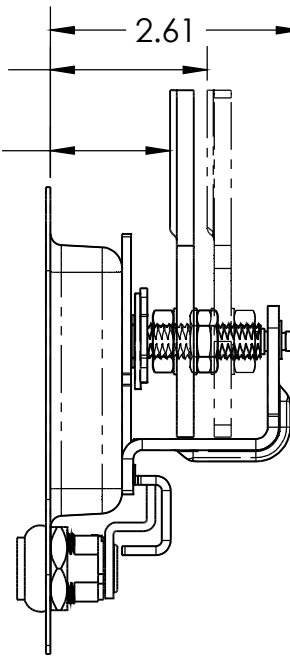

T-HANDLE CUTOUT

NOTES:

1. MATERIAL AND FINISH: POLISHED STAINLESS STEEL TRAY W/CHROME HANDLE. ALL OTHER COMPONENTS ARE ZINC PLATED OR STAINLESS STEEL.
2. = DENOTES DIMENSIONS THAT ARE EQUALLY SPACED ABOUT THE CENTERLINE.
3. DIMENSIONS ARE FOR REFERENCE ONLY.



DESCRIPTION: ASM. T-HANDLE RH SS W/MTG HOLES	Weight 1.33 LBS
Part Number: TS2701SRSPBMH	REV -

PROPRIETARY NOTICE: THIS DRAWING IS EXCLUSIVELY THE PROPERTY OF HANSEN INTERNATIONAL INC. AND SHALL NOT BE COPIED OR PASSED ON TO A THIRD PARTY WITHOUT OUR PRIOR WRITTEN APPROVAL. WE WILL RETAIN ALL RIGHTS FOR PATENT ISSUE OR REGISTRATION OF DESIGN.
 ©2018 Hansen International, Inc.