

FINAL LATCH PART NUMBER W/ KEY CYL.	ROTATION DIRECTION	TRAY FINISH	MOUNTING HOLES OR CD STUDS
GC2502LXBPCD	LH	BLACK POWDERCOAT	STUDS
GC2502LXBPMH	LH	BLACK POWDERCOAT	HOLES
GC2502LXCRC	LH	CHROME	STUDS
GC2502LXCRCMH	LH	CHROME	HOLES
GC2502XRXBPCD	RH	BLACK POWDERCOAT	STUDS
GC2502XRXBPMH	RH	BLACK POWDERCOAT	HOLES
GC2502XRXCRC	RH	CHROME	STUDS
GC2502XRXCRCMH	RH	CHROME	HOLES

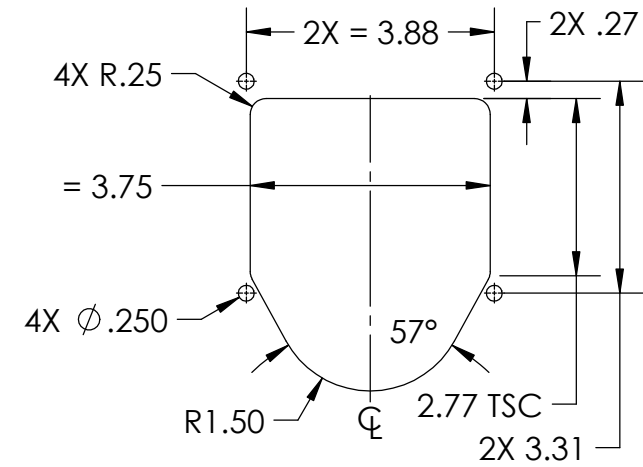

**RECOMMENDED CUTOUT SIZE**

2 POINT STUD KIT INCLUDED

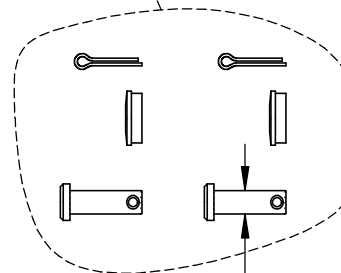

FOR Ø.250 ROD HOLE

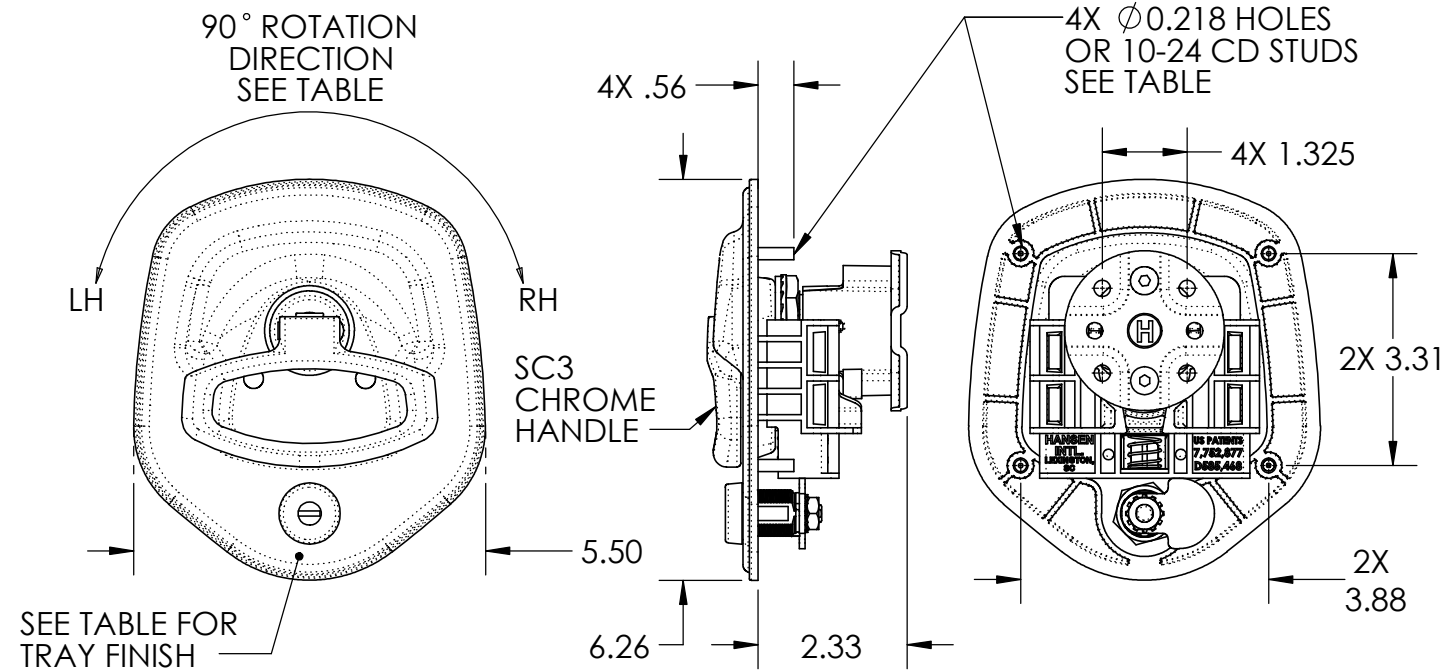

**NOTES:**

- MATERIALS : FORMED SHEET METAL TRAY WITH STEEL, ZINC ALLOY (ZAMAK) AND POLYMER INTERNALS
- FINISH : SEE TABLE
- DIMENSIONS ARE FOR REFERENCE ONLY



DESCRIPTION:	GUARDIAN 2 POINT HANDLE	Weight	2.3 LBS
Part Number:	GC2502XXXXXX	REV	-

PROPRIETARY NOTICE: THIS DRAWING IS EXCLUSIVELY THE PROPERTY OF HANSEN INTERNATIONAL INC. AND SHALL NOT BE COPIED OR PASSED ON TO A THIRD PARTY WITHOUT OUR PRIOR WRITTEN APPROVAL. WE WILL RETAIN ALL RIGHTS FOR PATENT ISSUE OR REGISTRATION OF DESIGN.  
©2018 Hansen International, Inc.