

FINAL LATCH PART NUMBER W/ KEY CYL.	ROTATION DIRECTION	TRAY FINISH	MOUNTING HOLES OR CD STUDS
GC2501XLXBPCD	LH	BLACK POWDERCOAT	STUDS
GC2501XLXBPMH	LH	BLACK POWDERCOAT	HOLES
GC2501XLXCRC	LH	CHROME	STUDS
GC2501XLXCRMH	LH	CHROME	HOLES
GC2501XRXBPCD	RH	BLACK POWDERCOAT	STUDS
GC2501XRXBPMH	RH	BLACK POWDERCOAT	HOLES
GC2501XRXCRC	RH	CHROME	STUDS
GC2501XRXCRMH	RH	CHROME	HOLES

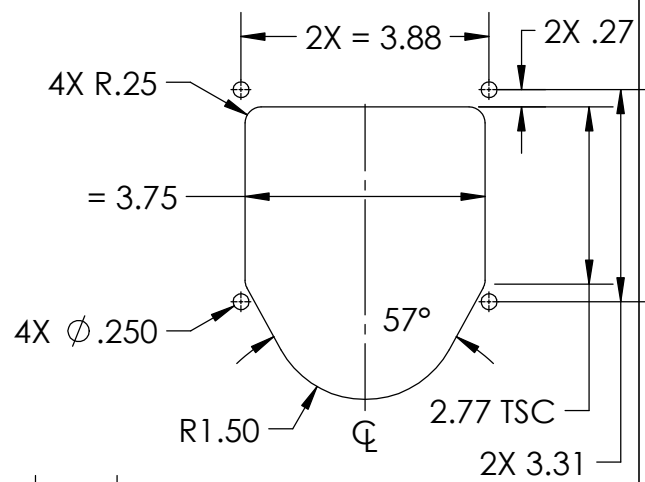

**RECOMMENDED CUTOUT SIZE**

STUD KIT FOR 3 POINT SOLD SEPARATELY SEE NOTE 3

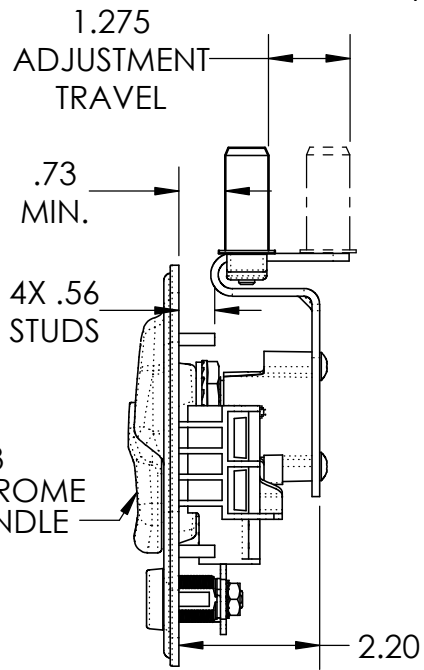
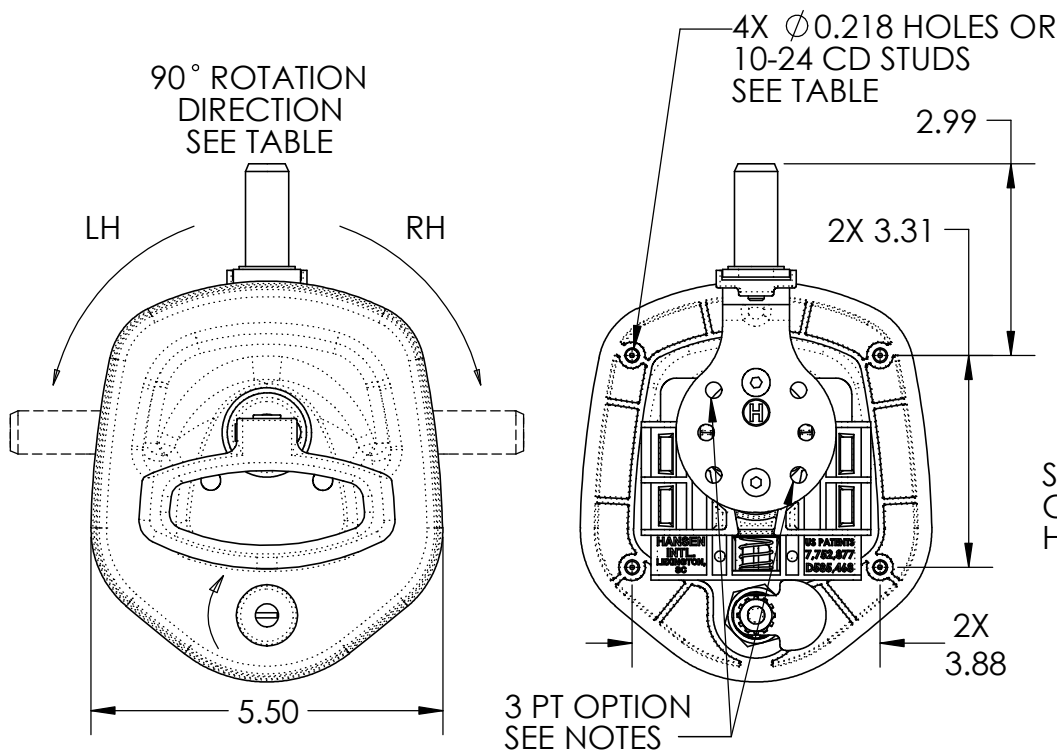
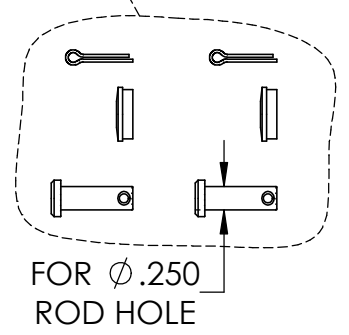

**NOTES:**

1. MATERIALS : FORMED SHEET METAL TRAY WITH STEEL, ZINC ALLOY (ZAMAK) AND POLYMER INTERNALS
2. FINISH : SEE TABLE
3. FOR 3 POINT OPTION, USE HANSEN STUD KIT P/N PMISC217
4. DIMENSIONS ARE FOR REFERENCE ONLY

**HANSEN**  
INTERNATIONAL, INC.

DESCRIPTION:	GUARDIAN COMPRESSION LATCH	Weight	2.3 LBS
Part Number:	GC2501XXXXXX	REV	-
<small>PROPRIETARY NOTICE: THIS DRAWING IS EXCLUSIVELY THE PROPERTY OF HANSEN INTERNATIONAL INC. AND SHALL NOT BE COPIED OR PASSED ON TO A THIRD PARTY WITHOUT OUR PRIOR WRITTEN APPROVAL. WE WILL RETAIN ALL RIGHTS FOR PATENT ISSUE OR REGISTRATION OF DESIGN. ©2018 Hansen International, Inc.</small>			