

NOTES:

1. MATERIAL AND FINISH: POLISHED STAINLESS STEEL TRAY AND HANDLE.
ALL OTHER COMPONENTS ARE STAINLESS STEEL OR ZINC PLATED STEEL.
2. DIMENSIONS ARE FOR REFERENCE ONLY.

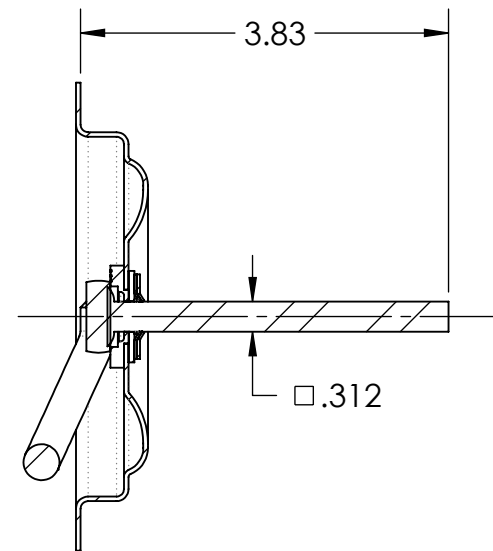

SECTION A-A

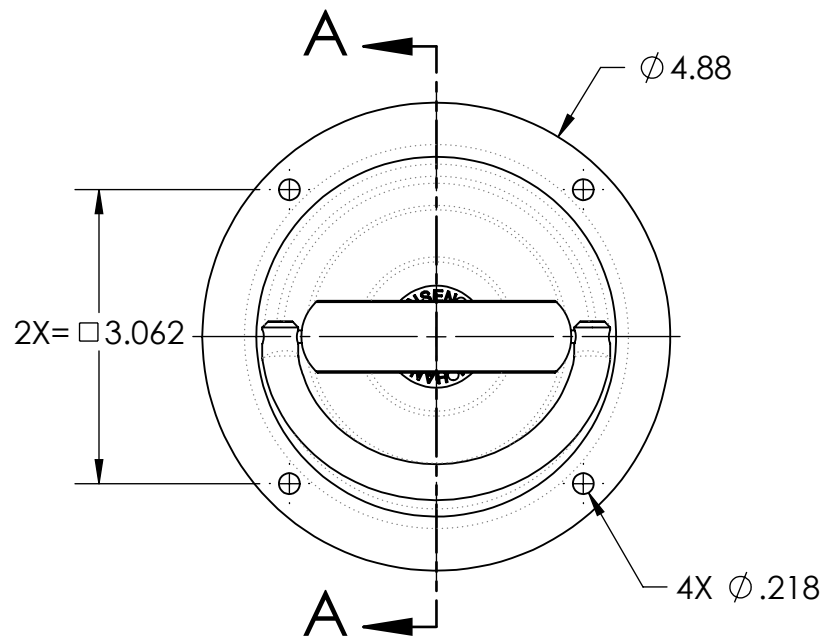
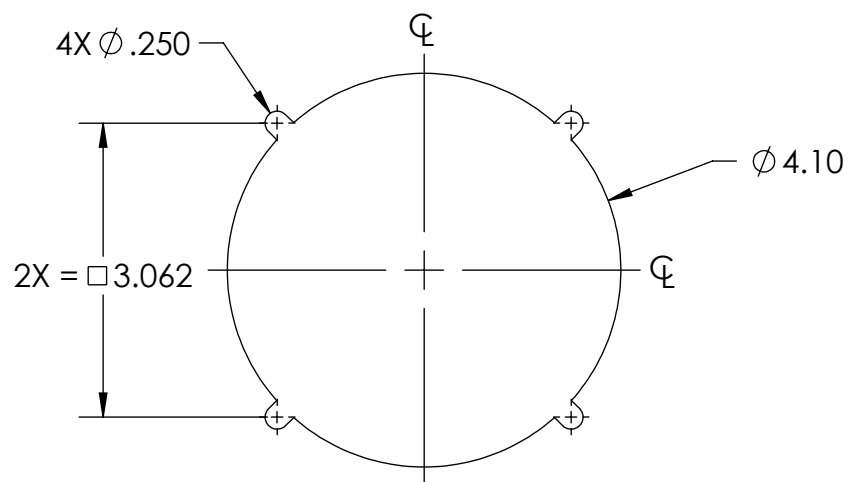

D-RING CUTOUT



DESCRIPTION:	#79-S ASSY (SS) W/MTG HOLES	Weight	.61 LBS
Part Number:	S79SXXXSPBXX	REV	1

PROPRIETARY NOTICE: THIS DRAWING IS EXCLUSIVELY THE PROPERTY OF HANSEN INTERNATIONAL INC. AND SHALL NOT BE COPIED OR PASSED ON TO A THIRD PARTY WITHOUT OUR PRIOR WRITTEN APPROVAL. WE WILL RETAIN ALL RIGHTS FOR PATENT ISSUE OR REGISTRATION OF DESIGN.
©2020 Hansen International, Inc.