

NOTES:

1. MATERIAL AND FINISH: CUP AND HANDLE ARE POLISHED S'STL. ALL OTHER COMPONENTS ARE ZINC PLATED STEEL.
2. DIMENSIONS ARE FOR REFERENCE ONLY.

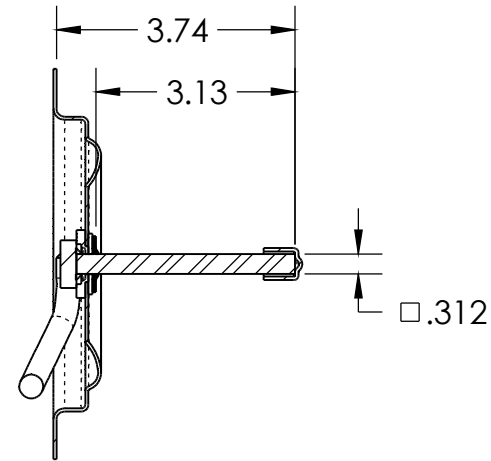

SECTION A-A

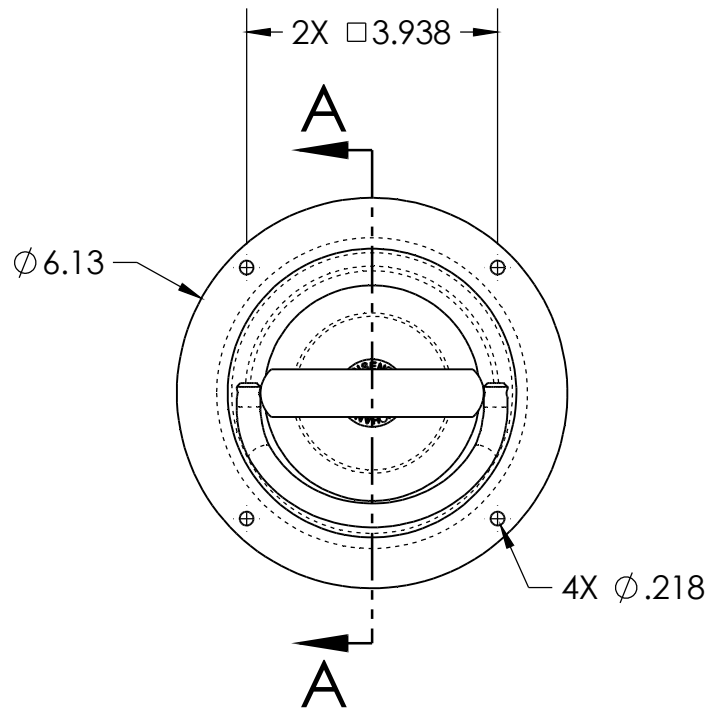
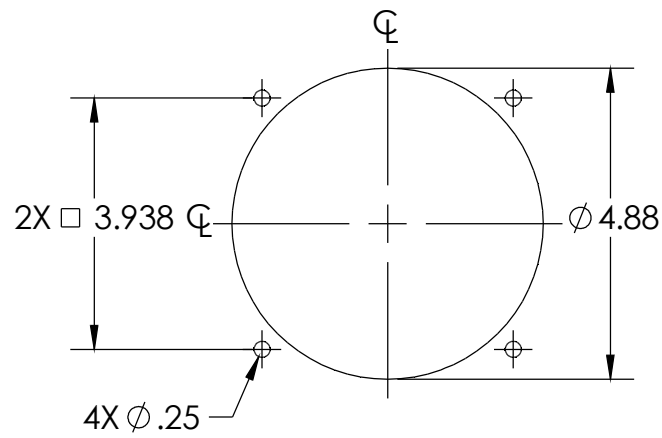

D-RING CUTOUT



DESCRIPTION:	ASSY - #79-L SS W/3.125 SHANK	Weight .81 LBS
Part Number:	F79-LXXSPBXX	REV -

PROPRIETARY NOTICE: THIS DRAWING IS EXCLUSIVELY THE PROPERTY OF HANSEN INTERNATIONAL INC. AND SHALL NOT BE COPIED OR PASSED ON TO A THIRD PARTY WITHOUT OUR PRIOR WRITTEN APPROVAL. WE WILL RETAIN ALL RIGHTS FOR PATENT ISSUE OR REGISTRATION OF DESIGN.  
©2018 Hansen International, Inc.