

SECTION A-A

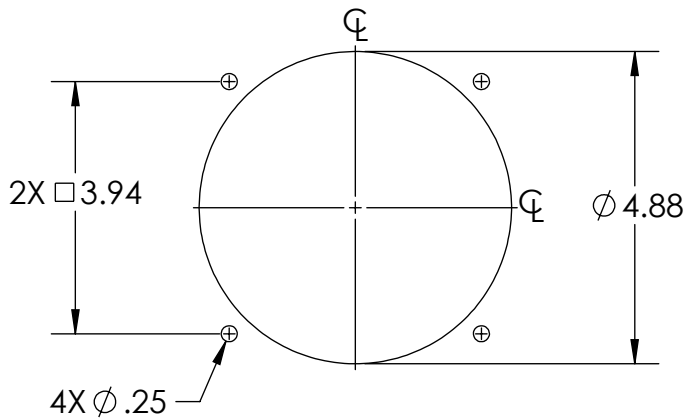
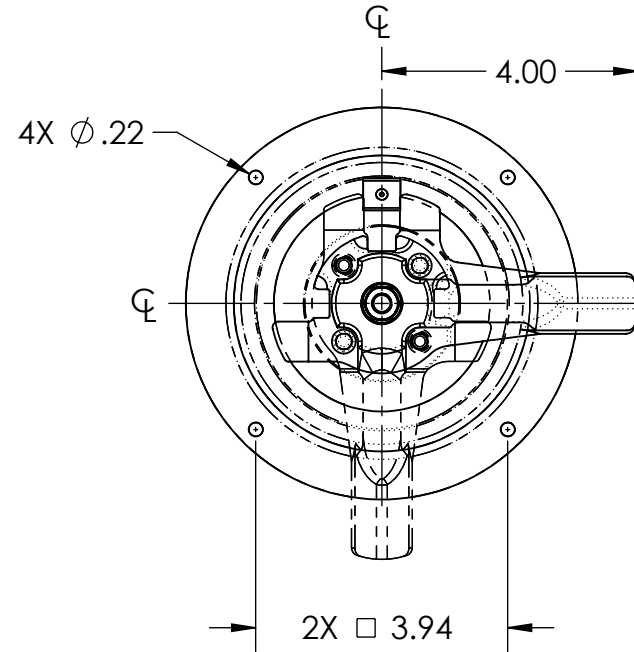

D-RING CUTOUT

NOTES:

1. FINISH AND MAT'L: POLISHED S'STL TRAY AND HANDLE. ALL OTHER COMPONENTS ARE S'STL OR ZINC PLATED STEEL.
2. DIMENSIONS ARE FOR REFERENCE ONLY.

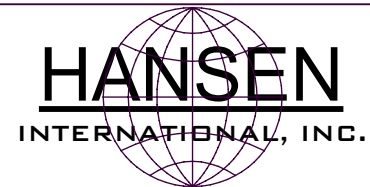

DESCRIPTION: 103-L ASSY (RH) S'STL W/MTG HOLES	Weight 1.1 LBS
Part Number: F103LXRSPBXX	REV -

PROPRIETARY NOTICE: THIS DRAWING IS EXCLUSIVELY THE PROPERTY OF HANSEN INTERNATIONAL INC. AND SHALL NOT BE COPIED OR PASSED ON TO A THIRD PARTY WITHOUT OUR PRIOR WRITTEN APPROVAL. WE WILL RETAIN ALL RIGHTS FOR PATENT ISSUE OR REGISTRATION OF DESIGN.  
©2018 Hansen International, Inc.